CGS
PERCORSI D'ACQUA

Novità News



Pag. 28
Sifone salvaspazio
"ISY-SIPHON"
Space-saving "siphon"
"ISY-SIPHON" >



Pag. 29
Sifone salvaspazio
"ISY-SIPHON" Plus
Space-saving "siphon"
"ISY-SIPHON" Plus <



Pag. 10
Scarico in PP/INOX
PP/Stainless steel waste >



Pag. 20
Scarico "AquaSwift Pro"
"AquaSwift Pro" waste <



Pag. 59
Colonna scarico vasca
Bath waste & overflow >



Pag. 65
Scarico "Skip-up 2.0"
"Skip-up 2.0" waste <



OPTIONS

Nei casi in cui gli articoli elencati in questo listino presentino accessori/varianti rispetto alle versioni standard, dette options sono identificate mediante lettere. Di seguito sono riportati i significati associati ad ogni lettera:

In cases where the items listed in this price list come with accessories or variations compared to the standard version, we have used letters to highlight the specific differences. Below are the meanings associated with each letter:

AD	<p>Articolo disponibile anche con adattatore per la trasformazione da "Skip-up" a "Sempre Aperto" Aggiungere "AD" alla fine del codice Incremento prezzo di XXX Esempio: Art. SKN330.01 € XXX + "AD" € XXX = SKN330.01AD € XXX Item also available with an adapter for transformation from "Skip-up" to "Free Flow" Add "AD" to the end of the code Price increase of € XXX Example: SKN330.01 € XXX + "AD" € XXX = SKN330.01AD € XXX</p>	
B	<p>Articolo disponibile anche con sistema di innesto rapido "QuikFix" Aggiungere "B" alla fine del codice Questa opzione non comporta alcun costo aggiuntivo Esempio: Art. SKN300.01 € XXX + "B" € XXX = SKN300.01B € XXX Item also available with the "QuikFix" quick coupling system Add "B" to the end of the code No additional cost Example: Art. SKN300.01 € XXX + "B" € XXX = SKN300.01B € XXX</p>	
CH	<p>Articolo disponibile anche con calotta di fissaggio asta in ottone Togliere "CH" dal codice Incremento prezzo di € XXX Esempio: Art. 004SCH.01 € XXX - "CH" (+€ XXX) = 004S.01 € XXX Item is also available with a brass rod fixing nut Remove "CH" from the code Price increase of € XXX Example: Art. 004SCH.01 € XXX - "CH" (+€ XXX) = 004S.01 € XXX</p>	
CP	<p>Articolo disponibile anche con controdado in plastica Sostituire "CO" con "CP" nel codice Riduzione prezzo di € XXX Esempio: Art. SKN301CO.01 € XXX, "CO" → "CP" -€ XXX = SKN301CP.01 € XXX Item is also available with a plastic locknut Replace "CO" with "CP" in the code Cost reduction of € XXX Example: Art. SKN301CO.01 € XXX, "CO" → "CP" -€ XXX = SKN301CP.01 € XXX</p>	
F	<p>Articolo disponibile anche con filtro removibile Aggiungere "F" all'interno del codice Incremento prezzo di € XXX Esempio: Art. SKN340.01 € XXX + "F" € XXX = SKN340F.01 € XXX Item also available with a removable filter Add "F" inside the code Price increase of € XXX Example: Art. SKN340.01 € XXX + "F" € XXX = SKN340F.01 € XXX</p>	
M	<p>Articolo disponibile anche con supporto in ottone per incollaggio Aggiungere "M" alla fine del codice Riduzione prezzo di € XXX Esempio: Art. SKN301.01 € XXX, + "M" -€ XXX = SKN301.01M € XXX Item also available with a brass bonding support Add "M" to the end of the code Cost reduction of € XXX Example: Art. SKN301.01 € XXX, + "M" -€ XXX = SKN301.01M € XXX</p>	
TK	<p>Articolo disponibile anche con sifone preassemblato Aggiungere "TK" prima del codice Incremento prezzo di € XXX Esempio: Art. 122-A.01 € XXX, + "TK" +€ XXX = TK122-A.01 € XXX Item also available with a pre-assembled siphon Add "TK" before the code Price increase of € XXX Example: Art. 122-A.01 € XXX, + "TK" +€ XXX = TK122-A.01 € XXX</p>	
Z	<p>Articolo disponibile anche con cover in metallo (Zama) Aggiungere "Z" alla fine del codice Riduzione prezzo di € XXX Esempio: Art. SKN230.01 € XXX, + "Z" (-€ XXX) = SKN230.01Z € XXX Item also available with a metal cover (Zamak) Add "Z" to the end of the code Cost reduction of € XXX Example: Art. SKN230.01 € XXX, + "Z" (-€ XXX) = SKN230.01Z € XXX</p>	

CODIFICA CODING

Esempio codice prodotto - Article code example **106-1.01+64-B**

1 - prodotto - product **106**
 2 - lunghezza - length **-1**
 3 - finitura - finishing **.01**
 4 - accessori - accessories **+64-B**



Esempio codice prodotto - Article code example **104-Plus-1.43**

1 - prodotto - product **104-Plus**
 2 - lunghezza - length **-1**
 3 - finitura - finishing **.43**
 4 - accessori - accessories



DESIGN

Possibili combinazioni di tappi e maniglie per colonne scarico vasca
 Possible plug & control knob matches for bath wastes & overflows

Cod... : Maniglia "6 gole", tappo ø 42 mm
 "6 groove" control knob, plug ø 42 mm



Cod... -A: Maniglia "6 gole", tappo ABS ø 72 mm
 "6 groove" control knob, ABS plug ø 72 mm



Cod... -L: Maniglia "6 gole", tappo ø 72 mm
 "6 groove" control knob, plug ø 72 mm



Cod... -M: Maniglia "Minimal", tappo ø 42 mm
 "Minimal" control knob, plug ø 42 mm



Cod... -MA: Maniglia "Minimal", tappo ABS ø 72 mm
 "Minimal" control knob, ABS plug ø 72 mm



Cod... -Plus: Maniglia "Minimal", tappo ø 72 mm
 "Minimal" control knob, plug ø 72 mm



FINITURE FINISHINGS

Riferimento listino Ref. price list	Descrizione Description	Codice Code
	Cromo Chrome	.01
	Ottone pulito Polished brass	.16
	Bianco opaco Matt white	.33
	Bianco eurowhite Eurowhite	.35
	Nero opaco Matt black	.43
	Bronzo antico Old bronze	.25
	Rame antico Old copper	.26
	Nickel spazzolato lucido Polished brushed nickel	.38
	Nickel spazzolato opaco Matt brushed nickel	.40
	Oro Gold	.12
PVD	Gun Metal	.11
Lucido Glossy	Copper	.76
	Gold	.04
PVD	Gun Metal Brushed	.09
Spazzolato Brushed	Copper Brushed	.77
	Gold Brushed	.07



< .01

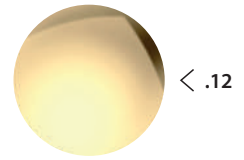

< .12

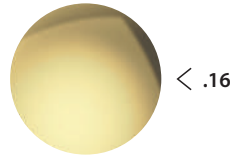

< .16



< .11



< .33

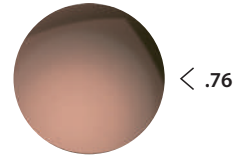

< .76

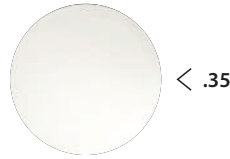

< .35

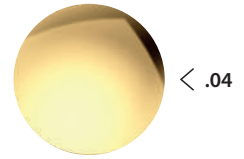

< .04



< .43

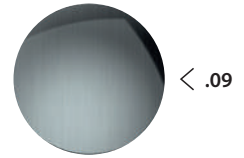

< .09

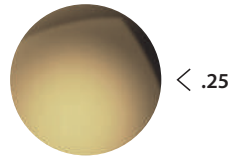

< .25



< .77

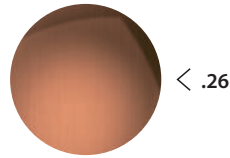

< .26

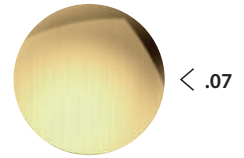

< .07



< .38



< .40



SKN330 **NF**

Scarico 1" 1/4 in ottone per lavabo mod. "Universale"
Brass waste 1" 1/4 for washbasin, "Universal" model

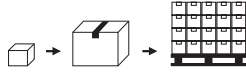

Imballo - Pack QxC QxB
Cod 1 50 1500

Options

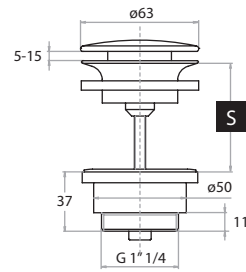

	Cod	S	mm	PVD				PVD Lucido Glossy	PVD Spazzolato Brushed
				.01	.33	.35	.43		
Skip-up 2.0	SKN330._	0-70	✓	✓	✓	✓	✓	✓	✓
Free-flow	SKN330._SA	0-70	✓	✓	✓	✓	✓	✓	✓

SKN340 **NF**

Scarico 1" 1/4 in ottone per lavabo mod. "Universale"
Tappo in ceramica
Brass waste 1" 1/4 with ceramic plug for washbasin,
"Universal" model

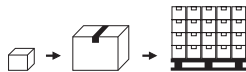

Imballo - Pack QxC QxB
Cod 1 25 750

Option

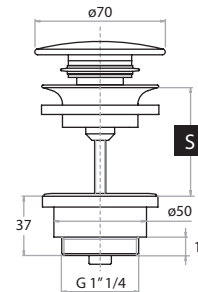

	Cod	S	mm
Skip-up 2.0	SKN340.01	0-70	✓
Free-flow	SKN340.01SA	0-70	✓

SKN350 **NF**

Scarico 1" 1/4 in ottone per lavabo mod. "Universale"
Tappo in Corian®
Brass waste 1" 1/4 with Corian® plug for washbasin,
"Universal" model

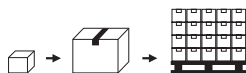

Imballo - Pack QxC QxB
Cod 1 25 750

Option

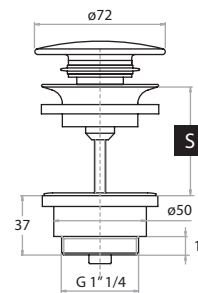

	Cod	S	mm
Skip-up 2.0	SKN350.01	0-70	✓
Free-flow	SKN350.01SA	0-70	✓

SKN330-INOX **NF**

Scarico 1" 1/4 in acciaio inox per lavabo mod. "Universale"
Stainless steel waste 1" 1/4 for washbasin, "Universal" model

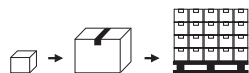

Imballo - Pack QxC QxB
Cod 1 50 1500

Option

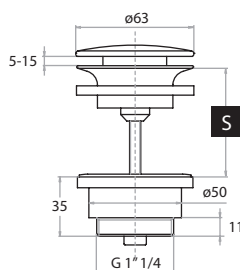

INOX

	Cod	S mm		PVD Spazzolato Brushed
	SKN330-INOX. __	0-70	✓	✓
	SKN330-INOX . __ SA	0-70	✓	✓

SKN230 **NF**

Scarico 1" 1/4 in ottone per lavabo mod. "Universale"
Brass waste 1" 1/4 for washbasin, "Universal" model



Imballo - Pack QxC QxB
Cod 1 50 1500

Options

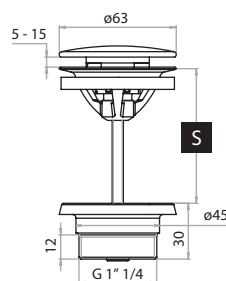

NEW

	Cod	S mm	.01	.33	.35	.43
	SKN230. __	5-70	✓	✓	✓	✓
	SKN230. __ SA	5-70	✓	✓	✓	✓

SKN230P **NF**

Scarico 1" 1/4 in ottone per lavabo mod. "Universale"
Tappo ABS con **copertura INOX**
Brass waste 1" 1/4 with ABS plug **INOX covering** for
washbasin, "Universal" model



Imballo - Pack QxC QxB
Cod 1 50 1500

Option

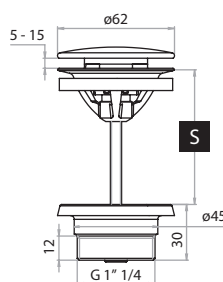

NEW

	Cod	S mm	
	SKN230.01P	5-70	✓
	SKN350.01SAP	5-70	✓

Per opzioni vedere risvolto di copertina
For options check the cover flap

SKN237

Scarico 1" 1/4 in ottone/inox per lavabo mod. "Universale"
Brass/stainless steel waste 1" 1/4 for washbasin,
"Universal" model

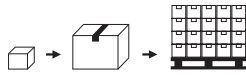

Imballo - Pack QxC QxB
Cod 1 50 1500

Options

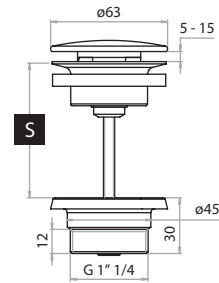

	Cod	S	mm	
	SKN237.01	8-70	✓	
	SKN237.01SA	8-70	✓	

SKN237P

Scarico 1" 1/4 in ottone/inox per lavabo mod. "Universale"
Tappo ABS con **copertura INOX**
Brass waste 1" 1/4 with ABS plug **INOX covering** for
washbasin, "Universal" model

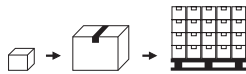

Imballo - Pack QxC QxB
Cod 1 50 1500

Option

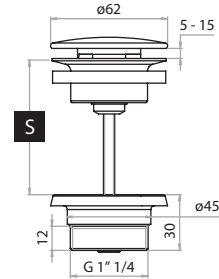

	Cod	S	mm	
	SKN237.01P	8-70	✓	
	SKN237.01SAP	8-70	✓	

SKN530 NF

Scarico 1" 1/4 in PP/inox per lavabo mod. "Universale",
innesto rapido
PP/stainless steel waste 1" 1/4 for washbasin, "Universal" model,
fast system

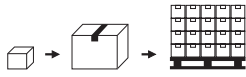

Imballo - Pack
Cod 1 50 1500

Options

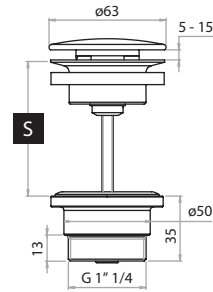

	Cod	S	mm	
	SKN530.01	5-70	✓	
	SKN530.01SA	5-70	✓	

SKN530P NF

Scarico 1" 1/4 in PP/inox per lavabo mod. "Universale"
Tappo ABS con **copertura INOX**
PP/stainless steel waste 1" 1/4 with ABS plug **INOX covering**
for washbasin, "Universal" model

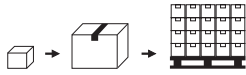

Imballo - Pack
Cod 1 50 1500

Options

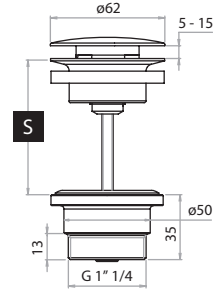

	Cod	S	mm	
	SKN530.01P	5-70	✓	
	SKN530.01SAP	5-70	✓	

SKN530-INOX NF

Scarico 1" 1/4 in acciaio inox per lavabo mod. "Universale"
Stainless steel waste 1" 1/4 for washbasin, "Universal" model

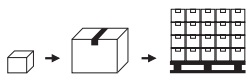

Imballo - Pack
Cod 1 50 1500

Option

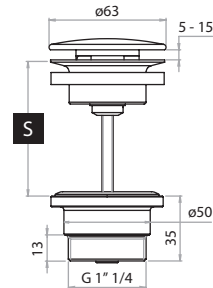

	Cod	S	mm	
	SKN530-INOX	5-70	✓	
	SKN530-INOXSA	5-70	✓	

Per opzioni vedere risvolto di copertina
For options check the cover flap

SKN530B **NF**

Scarico 1" 1/4 in PP/inox per lavabo mod. "Universale", sistema "QuikFix"
 PP/stainless steel waste 1" 1/4 for washbasin, "Universal" model, "QuikFix" system

Options

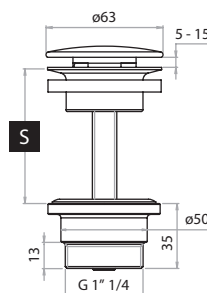

PATENT PENDING

NEW

	Cod	S	mm	
	SKN530.01B	0-70	✓	
	SKN530.01SAB	0-70	✓	

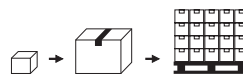

Imballo - Pack QxC QxB
 Cod 1 50 1500

SKN530PB **NF**

Scarico 1" 1/4 in PP/inox per lavabo mod. "Universale", sistema "QuikFix"
 Tappo ABS con **copertura INOX**
 PP/stainless steel waste 1" 1/4 with ABS plug **INOX covering**
 for washbasin, "Universal" model, "QuikFix" system

Option

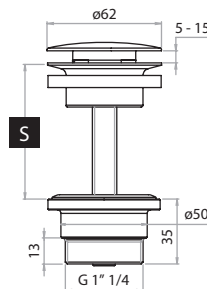

PATENT PENDING

NEW

	Cod	S	mm	
	SKN530.01PB	0-70	✓	
	SKN530.01SAPB	0-70	✓	

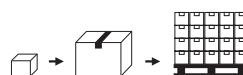

Imballo - Pack QxC QxB
 Cod 1 50 1500

SKN530-INOXB **NF**

Scarico 1" 1/4 in PP/acciaio inox per lavabo mod. "Universale", sistema "QuikFix"
 PP/stainless steel waste 1" 1/4 for washbasin, "Universal" model, "QuikFix" system

Option

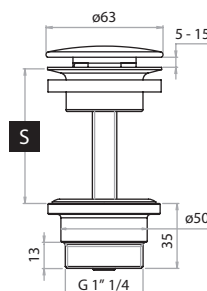

PATENT PENDING

NEW

	Cod	S	mm	
	SKN530-INOXB	0-70	✓	
	SKN530-INOXSAB	0-70	✓	

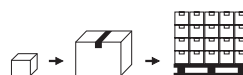

Imballo - Pack QxC QxB
 Cod 1 50 1500



SKN550

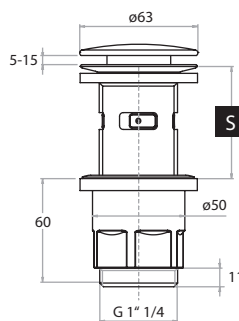

Scarico 1" 1/4 in ABS per lavabo mod. "Universale"
 Adattatore sistema "QuikFix" per trasformazione
 in versione **sempre aperto**
 ABS waste 1" 1/4 for washbasin, "Universal" model
 "QuikFix" system adapter for free flow version

Option

M



	Cod	 mm	
 Skip-up 2.0	SKN550.01	0-80	✓



Imballo - Pack			
Cod	1	50	1500

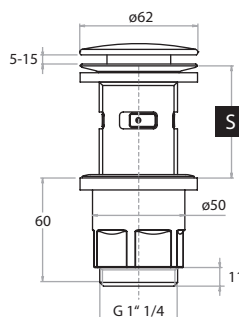

SKN550P

Scarico 1" 1/4 in ABS per lavabo mod. "Universale"
 Tappo ABS con **copertura INOX**
 Adattatore sistema "QuikFix" per trasformazione in versione
sempre aperto
 ABS waste 1" 1/4 with ABS plug **INOX covering** for washbasin,
 "Universal" model
 "QuikFix" system adapter for free flow version



NEW

	Cod	 mm	
 Skip-up 2.0	SKN550.01P	0-80	✓

Imballo - Pack			
Cod	1	50	1500

SKN300 NF

Scarico 1" 1/4 in ottone per lavabo **con troppo pieno**
Brass waste 1" 1/4 for washbasin **with overflow**

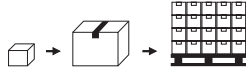

Imballo - Pack		QxC	QxB
Cod	1	50	1500
Cod-1, Cod-2	1	25	750

Options

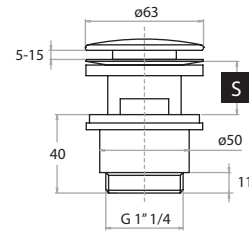

		S								PVD Lucido Glossy	PVD Spazzolato Brushed	
	Cod	mm	.01	.33	.35	.43	.25	.26	.38	.40	.12	
Skip-up 2.0	SKN300._ _	30-45	✓		✓						✓	✓
	SKN300-1._ _	46-60	✓		✓						✓	✓
	SKN300-2._ _	70-85	✓		✓						✓	✓
Free-flow	SKN300._ _SA	30-45	✓		✓						✓	✓
	SKN300-1._ _SA	46-60	✓		✓						✓	✓
	SKN300-2._ _SA	70-85	✓		✓						✓	✓

SKN301 NF

Scarico 1" 1/4 in ottone per lavabo **senza troppo pieno**
Brass waste 1" 1/4 for washbasin **without overflow**

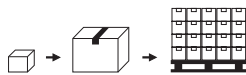

Imballo - Pack		QxC	QxB
Cod	1	50	1500
Cod-1, Cod-2	1	25	750

Options

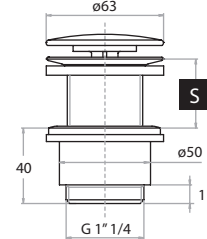

		S									PVD Lucido Glossy	PVD Spazzolato Brushed
	Cod	mm	.01	.33	.35	.43	.25	.26	.38	.40	.12	
Skip-up 2.0	SKN301._ _	30-45	✓		✓						✓	✓
	SKN301-1._ _	46-60	✓		✓						✓	✓
	SKN301-2._ _	70-85	✓		✓						✓	✓
Free-flow	SKN301._ _SA	30-45	✓		✓						✓	✓
	SKN301-1._ _SA	46-60	✓		✓						✓	✓
	SKN301-2._ _SA	70-85	✓		✓						✓	✓

SKN300-1CO

Scarico 1" 1/4 in ottone per lavabo **con troppo pieno**
Controdado ottone
Brass waste 1" 1/4 with brass lock nut, for washbasin **with overflow**



Imballo - Pack		QxC	QxB
Cod	1	25	750

Options

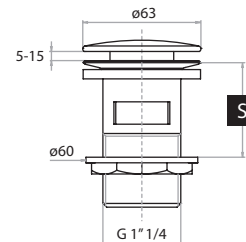

		S									PVD Lucido Glossy	PVD Spazzolato Brushed
	Cod	mm	.01	.33	.35	.43	.25	.26	.38	.40	.12	
Free-flow	SKN300-1CO._ _	30-50	✓		✓						✓	✓
	SKN300-2CO._ _	30-75	✓		✓						✓	✓
Free-flow	SKN300-1CO._ _SA	30-50	✓		✓						✓	✓
	SKN300-2CO._ _SA	30-75	✓		✓						✓	✓

SKN301CO

Scarico 1" 1/4 in ottone per lavabo **con troppo pieno**
 Controdado ottone
 Brass waste 1" 1/4 with brass lock nut, for washbasin **with overflow**

Options

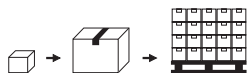
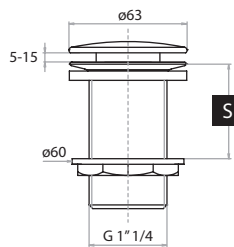

Imballo - Pack	QxC	QxB
Cod	1 50	1500
Cod-1, Cod-2	1 25	750

	Cod	S	mm	.01	.33	.35	.43	.25	.26	.38	.40	.12	PVD Lucido Glossy	PVD Spazzolato Brushed
Skip-up 2.0	SKN301CO._.	5-35	✓		✓				✓			✓	✓	✓
	SKN301-1CO._.	5-50	✓		✓				✓			✓	✓	✓
	SKN301-2CO._.	5-75	✓		✓				✓			✓	✓	✓
Free-flow	SKN301CO._.SA	5-35	✓		✓				✓			✓	✓	✓
	SKN301-1CO._.SA	5-50	✓		✓				✓			✓	✓	✓
	SKN301-2CO._.SA	5-75	✓		✓				✓			✓	✓	✓

SK370

Scarico 1" 1/4 in ottone per lavabo **con troppo pieno**
 Tappo ø 36 mm
 Brass waste 1" 1/4 for washbasin **with overflow**,
 plug ø 36 mm



Imballo - Pack	QxC	QxB
Cod	1 25	750

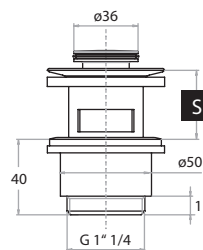

	Cod	S	mm	✓
Skip-up	SKN370.01	30-45	✓	

SK371

Scarico 1" 1/4 in ottone per lavabo **senza troppo pieno**
 Tappo ø 36 mm
 Brass waste 1" 1/4 for washbasin **without overflow**,
 plug ø 36 mm

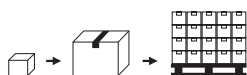

Imballo - Pack	QxC	QxB
Cod	1 25	750

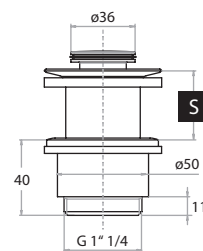

	Cod	S	mm	✓
Skip-up	SKN371.01	30-45	✓	

Per opzioni vedere risvolto di copertina
 For options check the cover flap

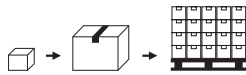

SK500

Scarico 1" 1/4 in polipropilene per lavabo **con troppo pieno**, tappo in polipropilene ricoperto acciaio
 Polypropylene waste 1" 1/4 with stainless steel wrapped polypropylene plug, for washbasin **with overflow**

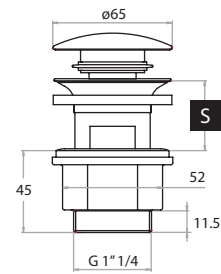

Imballo - Pack	1	QxC	50	QxB	1500
Cod					



	Cod	 mm	
 Skip-up	SK500.01	30-45	✓

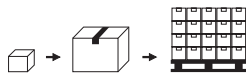

SK501

Scarico 1" 1/4 in polipropilene per lavabo **senza troppo pieno**, tappo in polipropilene ricoperto acciaio
 Polypropylene waste 1" 1/4 with stainless steel wrapped polypropylene plug, for washbasin **without overflow**

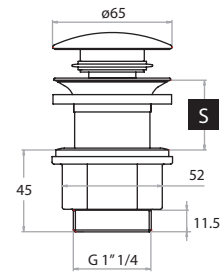

Imballo - Pack	1	QxC	50	QxB	1500
Cod					



	Cod	 mm	
 Skip-up	SK501.01	30-45	✓

200RS

Scarico 1" 1/4 in ottone per lavabo **con troppo pieno**,
 versione **sempre aperto** con griglia, raccordo ottagonale sabbiato
 Brass waste 1" 1/4 with grid, for washbasin **with overflow**
Free flowing drain, with sandblasted plated octagonal connection



Imballo - Pack	1	QxC	50	QxB	750
Cod	1	50	750		

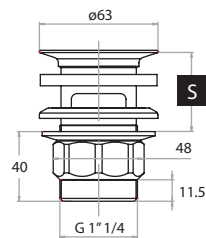

	S	
Cod	mm	
200RS.01	30-45	✓

201RS

Scarico 1" 1/4 in ottone per lavabo **senza troppo pieno**,
 versione **sempre aperto** con griglia, raccordo ottagonale sabbiato
 Brass waste 1" 1/4 with grid, for washbasin **without overflow**
Free flowing drain, with sandblasted plated octagonal connection



Imballo - Pack	1	QxC	50	QxB	750
Cod	1	50	750		

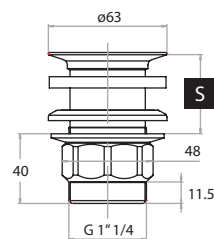

	S	
Cod	mm	
201RS.01	30-45	✓

201CO

Scarico 1" 1/4 in ottone per lavabo **senza troppo pieno**,
 versione **sempre aperto** con griglia, controdado ottone
 Brass waste 1" 1/4 with grid, for washbasin **without overflow**
Free flowing drain with brass nut



Imballo - Pack	1	QxC	50	QxB	750
Cod	1	50	750		

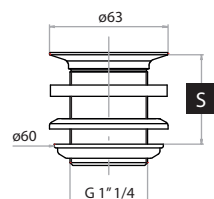

	S	
Cod	mm	
201CO.01	30-45	✓

200

Scarico 1" 1/4 in ottone per lavabo **con troppo pieno**,
versione **sempre aperto** con griglia, raccordo cilindrico
Brass waste 1" 1/4 with grid, for washbasin **with overflow**
Free flowing drain, with polished plated round connection

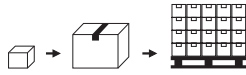

Imballo - Pack	QxC	QxB
Cod	1	50
		750

	S	
Cod	mm	
200.01	30-45	✓

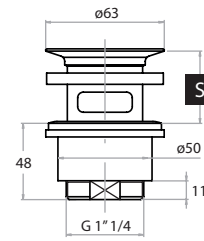

201

Scarico 1" 1/4 in ottone per lavabo **senza troppo pieno**,
versione **sempre aperto** con griglia, raccordo cilindrico
Brass waste 1" 1/4 with grid, for washbasin **without overflow**
Free flowing drain, with polished plated round connection

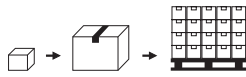

Imballo - Pack	QxC	QxB
Cod	1	50
		750

	S	
Cod	mm	
201.01	30-45	✓

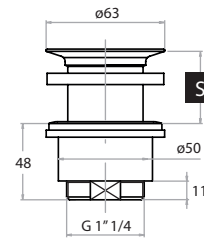

200RL

Scarico 1" 1/4 in ottone per lavabo **con troppo pieno**,
versione **sempre aperto** con griglia, raccordo ottagonale
Brass waste 1" 1/4 with grid, for washbasin **with overflow**
Free flowing drain, with polished plated octagonal connection

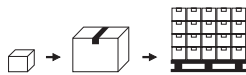

Imballo - Pack	QxC	QxB
Cod	1	50
		750

	S	
Cod	mm	
200RL.01	30-45	✓

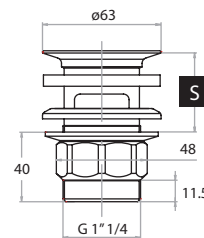

201RL

Scarico 1" 1/4 in ottone per lavabo **senza troppo pieno**,
versione **sempre aperto** con griglia, raccordo ottagonale
Brass waste 1" 1/4 with grid, for washbasin **without overflow**
Free flowing drain, with polished plated octagonal connection

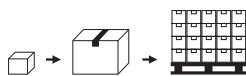

Imballo - Pack	QxC	QxB
Cod	1	50
		750

	S	
Cod	mm	
201RL.01	30-45	✓

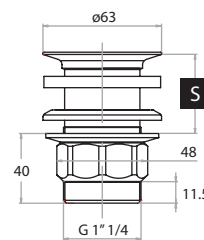



Scarico ottone 1" 1/4 sabbiaio, calotta plastica, asta acciaio
 1" 1/4 sandblasted brass washbasin waste with plastic coupling, stainless steel shaft

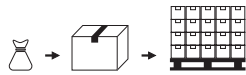

Imballo - Pack	QxC	QxB
Cod 004SCH	1 60	900
Cod 004SPCH	1 60	1440
Cod 004CH	1 60	900
Cod 004LCH	1 60	900

Option

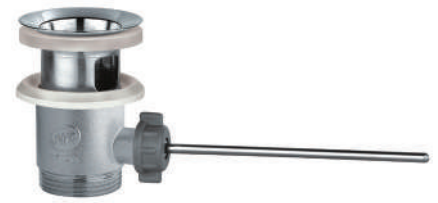
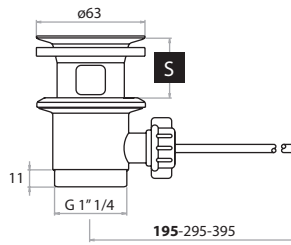

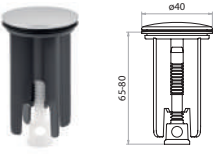
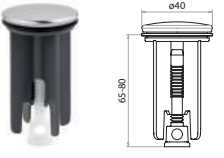
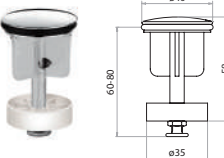
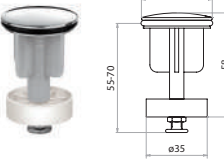
Cod	S	mm	Color				PVD				
			.01	.33	.35	.43	.25	.26	.38	.40	.12
 Tappo SNAP ottone SNAP brass plug 004SCH._._ 30-50	✓	✓	✓	✓	✓	✓	✓	✓	✓	✓	✓
 Tappo SNAP acciaio INOX SNAP Stainless steel plug 004SPCH._._ 30-50	✓										
 Tappo ottone Brass plug 004CH._._ 30-50	✓	✓	✓	✓	✓	✓	✓	✓	✓		
 Tappo ottone, ali plastica Brass plug, plastic stem 004LCH._._ 30-50	✓	✓	✓	✓	✓	✓	✓	✓	✓		

P04 • PA04 • P65 

Scarico 1" 1/4 "AquaSwift Pro" in PP, calotta plastica, asta acciaio

PP 1" 1/4 "AquaSwift Pro" washbasin waste with plastic coupling, stainless steel shaft

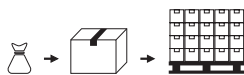

Imballo - Pack	QxC	QxB
Cod P04SCH 1	60	1440
Cod PA04SPCH 1	60	1440
Cod P65SCH 1	60	720
Cod P65SCHZ 1	60	720

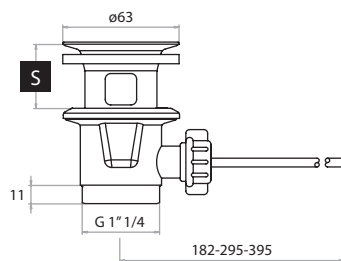

PATENT PENDING

NEW

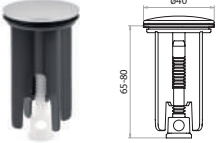
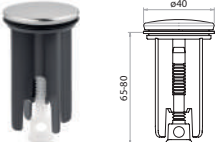
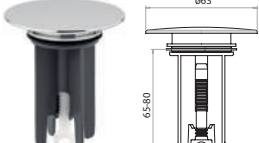
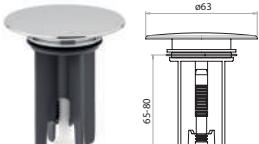
	Cod	S	mm	
 <p>Tappo SNAP ottone SNAP brass plug</p>	P04SCH.01		30-50	✓
 <p>Tappo SNAP acciaio INOX SNAP Stainless steel plug</p>	PA04SPCH.01		30-50	✓
 <p>Tappo SNAP ottone SNAP brass plug</p>	P65SCH.01		30-50	✓
 <p>Tappo SNAP Zama SNAP Zama plug</p>	P65SCH.01Z		30-50	✓

065 • 075 • 085

Scarico ottone 1" 1/4 sabbato, calotta ottone,
asta acciaio
1" 1/4 sandblasted brass washbasin waste with brass
coupling, stainless steel shaft



Imballo - Pack		QxC	QxB
Cod 065S	1	60	720
Cod 065	1	60	720

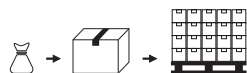

Imballo - Pack		QxC	QxB
Cod 075S	1	60	720
Cod 085S	1	60	720

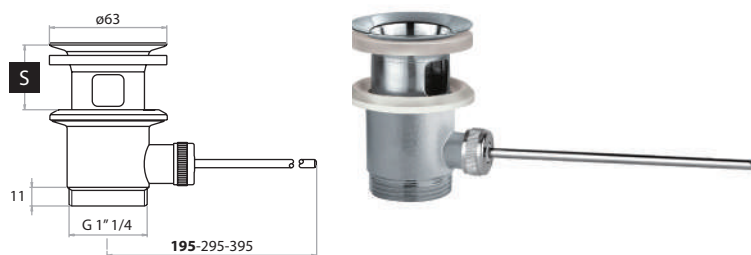

Cod	S	mm	Color							
			.01	.33	.35	.43	.25	.26	.38	.40
 Tappo SNAP ottone SNAP brass plug 065S._	30-50	✓		✓			✓			✓
 Tappo ottone, ali plastica Brass plug, plastic stem 065._	30-50	✓		✓			✓			✓
 Tappo SNAP ceramica SNAP ceramic plug 075S.01	30-50	✓								
 Tappo SNAP Corian® SNAP Corian® plug 085S.01	30-50	✓								

Scarico ottone 1" 1/4 lucido, calotta ottone, asta acciaio
 1" 1/4 polished brass washbasin waste with brass coupling, stainless steel shaft

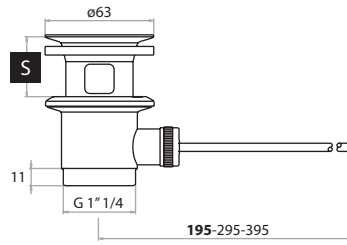
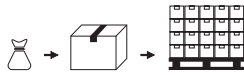

Imballo - Pack		QxC	QxB
Cod 001S	1	60	900
Cod 001	1	60	720
Cod 001L	1	60	900

	Cod	mm	S									
				.01	.33	.35	.43	.25	.26	.38	.40	.12
 Tappo SNAP ottone SNAP brass plug	001S._ _	30-50	✓		✓			✓			✓	
 Tappo ottone Brass plug	001._ _	30-50	✓		✓			✓			✓	
 Tappo ottone, ali plastica Brass plug, plastic stem	001L._ _	30-50	✓		✓			✓			✓	

Scarico ottone 1" 1/4 lucido, calotta ottone, asta acciaio
 1" 1/4 polished brass washbasin waste with brass coupling, stainless steel shaft

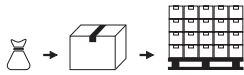

Imballo - Pack	QxC	QxB
Cod 060S	1 60	720
Cod 060	1 60	720

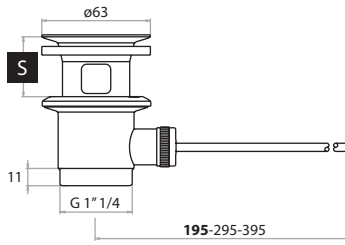

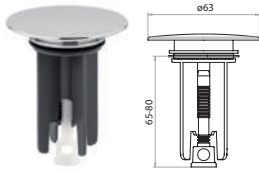
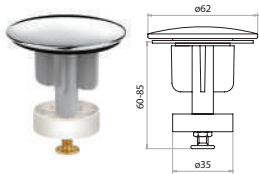
Cod	S mm	Color options									
		.01	.33	.35	.43	.25	.26	.38	.40	.12	
 <p>Tappo SNAP ottone SNAP brass plug</p>	30-50	✓		✓			✓			✓	
 <p>Tappo ottone, ali plastica Brass plug, plastic stem</p>	30-50	✓		✓			✓			✓	

008

Scarico ottone 1" 1/4 lucido, asta di comando manuale, calotta ottone, tappo ottone
 1" 1/4 polished brass pop-up washbasin waste, hand controlled, brass coupling and brass plug

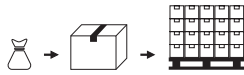

Imballo - Pack	1	QxC	60	QxB	720
Cod					

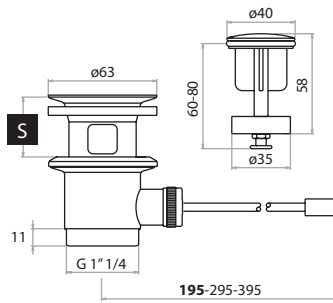

Cod	S	mm
008.01		30-45

015

Scarico ottone 1" 1/4 sabbia ridotto, tappo ottone, calotta ottone, asta acciaio
 1" 1/4 sandblasted brass reduced-size pop-up washbasin waste with brass coupling, stainless steel shaft and complete reduced-size brass plug

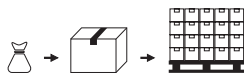

Imballo - Pack	1	QxC	60	QxB	900
Cod 015					

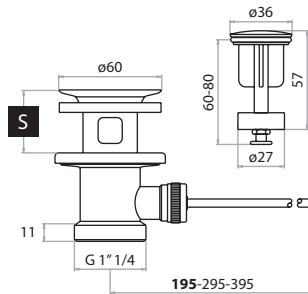

Cod	S	mm	.01	.33 .35 .43	.25 .26 .38 .40	.12
015._ _		30-45	✓	✓	✓	✓

015PCH

Scarico ottone 1" 1/4 sabbia ridotto, tappo plastica, calotta plastica, asta acciaio
 1" 1/4 sandblasted brass reduced-size pop-up washbasin waste with plastic coupling, stainless steel shaft and reduced-size plastic plug

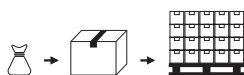

Imballo - Pack	1	QxC	60	QxB	1440
Cod 015CH.01					

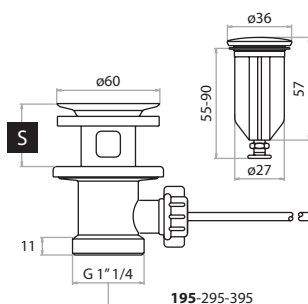

Cod	S	mm
015PCH.01		30-45

033

Scarico ottone 1" lusso sabbia, calotta plastica, asta acciaio
 1" sandblasted brass luxury pop-up washbasin, brass coupling, stainless steel shaft

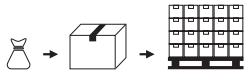

Imballo - Pack	QxC	QxB
Cod 033CH	1 60	720
Cod 033LCH	1 60	720
Cod 033ACH	1 60	720
Cod 033PCH	1 60	720

Option

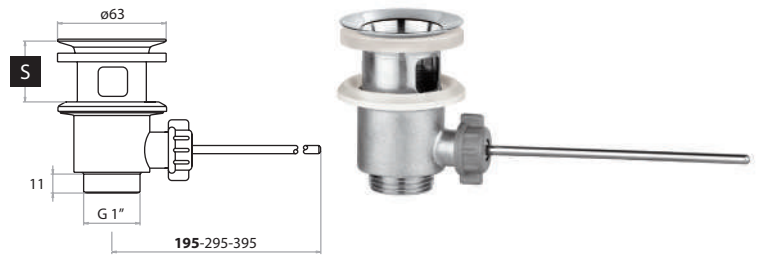

Cod	mm	S									
		.01	.33	.35	.43	.25	.26	.38	.40	.12	
 <p>Tappo ottone Brass plug</p> <p>033CH._ _</p> <p>30-50</p>	30-50	✓		✓			✓			✓	
 <p>Tappo ottone, ali plastica Brass plug, plastic stem</p> <p>033LCH._ _</p> <p>30-50</p>	30-50	✓		✓			✓			✓	
 <p>Tappo ottone, ali plastica, vite antifurto Brass plug, plastic stem, mounted with anti-theft screw</p> <p>033ACH._ _</p> <p>30-50</p>	30-50	✓		✓			✓			✓	
 <p>Tappo PP acciaio INOX PP plug, stainless steel</p> <p>033PCH.01</p> <p>30-50</p>	30-50	✓									

045

Scarico ottone 1" sabbia ECO, calotta ottone,
 asta acciaio
 1" ECONOMICAL sandblasted brass pop-up
 washbasin waste, brass coupling, stainless steel shaft

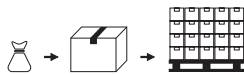

Imballo - Pack		QxC	QxB
Cod 045	1	60	720
Cod 045PCH	1	60	1440

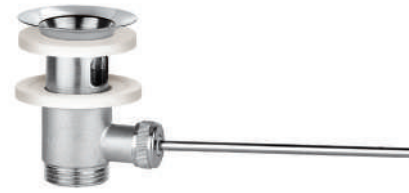
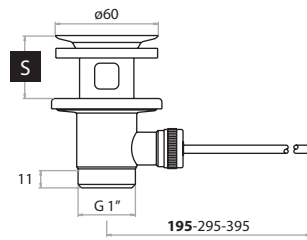

	Cod	mm	S									
			.01	.33	.35	.43	.25	.26	.38	.40	.12	
<p>Tappo ottone 1" 1" brass plug</p>	045._ _	30-50	✓		✓			✓				✓
<p>Tappo PP acciaio INOX PP plug, stainless steel</p>	045PCH.01	30-50	✓									

AL400

Sifone 1" 1/4 per lavabo modello quadro

- Materiale: ottone
- Minimale

Minimal 1" 1/4 square design brass washbasin bottle trap

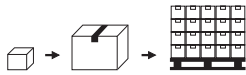

Imballo - Pack	1	QxC	10	QxB	180
Cod	1	10	180		

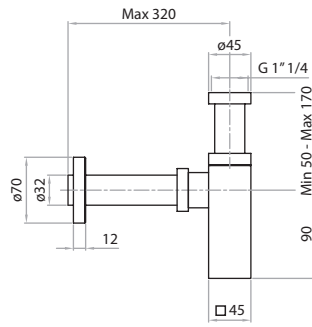

Cod	Color	Color	Color	Color	Color	Color	Color	Color	Color
	.01	.33	.35	.43	.25	.26	.38	.40	.12
AL400._ _	✓		✓			✓			✓

AL500

Sifone 1" 1/4 per lavabo modello quadro

- Materiale: ottone
- Minimale

Minimal 1" 1/4 square design brass washbasin bottle trap

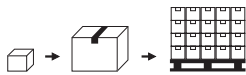

Imballo - Pack	1	QxC	10	QxB	180
Cod	1	10	180		

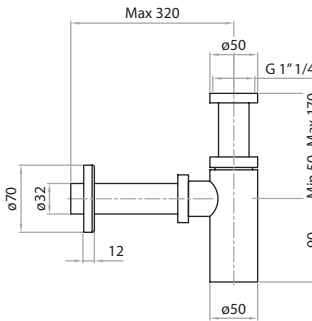

Cod	Color	Color	Color	Color	Color	Color	Color	Color	PVD Lucido Glossy	PVD Spazzolato Brushed	
	.01	.33	.35	.43	.25	.26	.38	.40	.12		
AL500._ _	✓		✓			✓			✓	✓	

AL520

Sifone salva spazio per lavabo con filetto per pileta 1" 1/4

- Materiale: ottone
- Scarico orizzontale

Space saving 1" 1/4 brass washbasin bottle trap
ø 32 mm horizontal wall outlet



Imballo - Pack	1
Cod	1

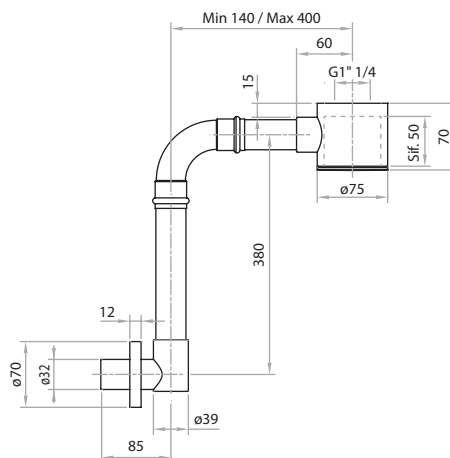

Cod	AL520.01	✓
-----	----------	---

AL800

Sifone salvaspazio "ISY-SIPHON", 1" 1/4

- Ispezione facilitata con clip a sgancio rapido
- Tubi ad innesto rapido
- Space-saving siphon "ISY-SIPHON", 1" 1/4
- Easy inspection with quick release clip
- Quick coupling tubes

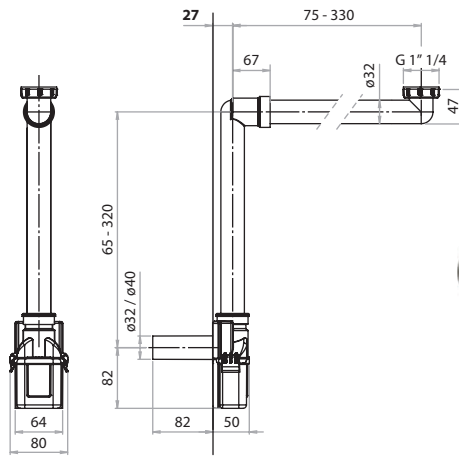

PATENT PENDING

NEW

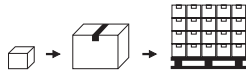

Imballo - Pack	QxC	QxB
Cod 1	20	260

Cod

AL800	✓
-------	---

AL800F

Sifone salvaspazio "ISY-SIPHON" 1" 1/4

- Ispezione facilitata con clip a sgancio rapido
- Tubi ad innesto rapido
- Filtro "TWIST IT ISY"
- Space-saving siphon "ISY-SIPHON", 1" 1/4
- Easy inspection with quick release clip
- Quick coupling tubes
- "TWIST IT ISY" filter

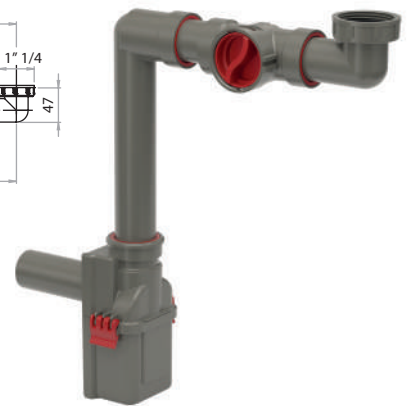
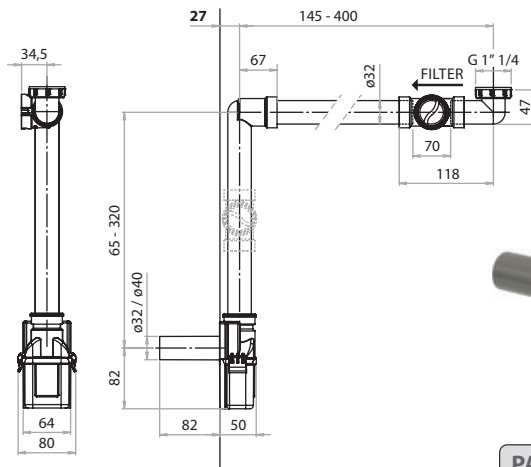

PATENT PENDING

NEW

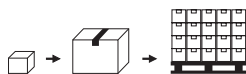

Imballo - Pack	QxC	QxB
Cod 1	20	260

Cod

AL800F	✓
--------	---

AL830

Sifone salvaspazio "ISY-SIPHON" Plus

- Ispezione facilitata con clip a sgancio rapido
- Tubi ad innesto rapido
- Completa di scarico "Skip-up 2.0"
- Tappo ottone sistema "QuikFix"
- Per spessore 5-70 mm

Space-saving siphon "ISY SIPHON" Plus

- Easy inspection with quick release clip
- Quick coupling tubes
- Complete with "Skip-up 2.0" waste
- "QuikFix" system brass plug
- For thickness 5-70 mm

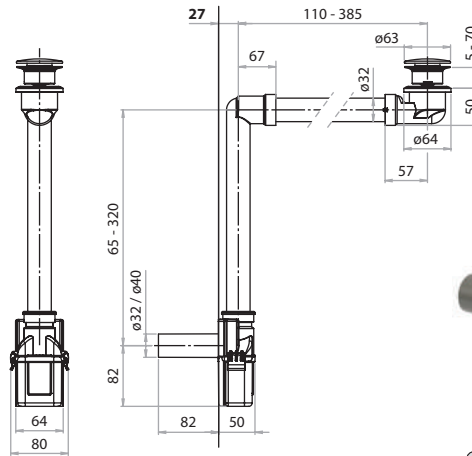

PATENT PENDING

NEW

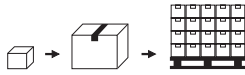

Imballo - Pack	QxC	QxB	
Cod	1	20	260

Cod

AL830.01



AL830F

Sifone salvaspazio "ISY-SIPHON" Plus

- Ispezione facilitata con clip a sgancio rapido
- Tubi ad innesto rapido
- Completa di scarico "Skip-up 2.0"
- Tappo ottone sistema "QuikFix"
- Per spessore 5-70 mm
- Filtro "TWIST IT ISY"

Space-saving siphon "ISY SIPHON" Plus

- Easy inspection with quick release clip
- Quick coupling tubes
- Complete with "Skip-up 2.0" waste
- "QuikFix" system brass plug
- For thickness 5-70 mm
- "TWIST IT ISY" filter

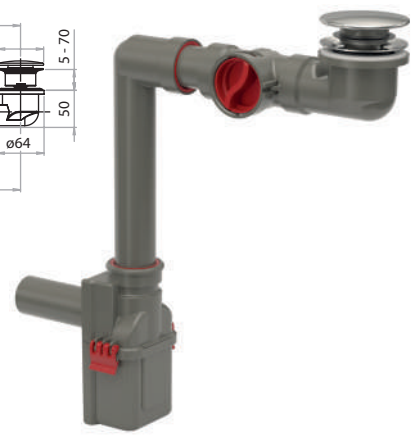
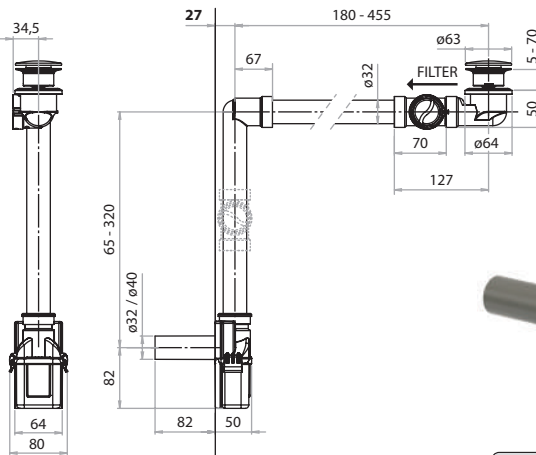

PATENT PENDING

NEW

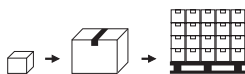

Imballo - Pack	QxC	QxB	
Cod	1	20	260

Cod

AL830F.01



AL063

Distanziale lavabo \varnothing 63 mm, H 13 mm per "ISY-SIPHON"
 \varnothing 63 mm H 13 mm washbasin spacer for "ISY-SIPHON"

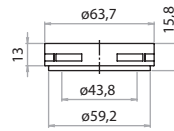

NEW

Cod

AL063	✓
-------	---

ASF800

Filtro per "ISY-SIPHON" serie AL800
Filter for AL800 series "ISY-SIPHON"

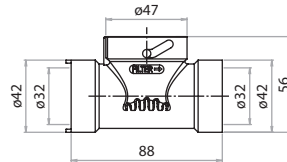

NEW

Cod

ASF800	✓
--------	---

ASF830

Filtro per "ISY-SIPHON" serie AL830
Filter for AL830 series "ISY-SIPHON"

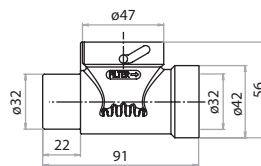

NEW

Cod

ASF830	✓
--------	---

AL140

Rubinetto arresto sottolavabo quadro

- Materiale: ottone
 - Con filtro
 - 1/2" M x 3/8" M
 - Attacco tubetto ø 10 mm
- Brass angle valve with filter
- 1/2" male connection
 - Square design
 - ø 10 mm inlet connection

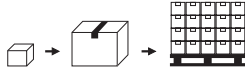
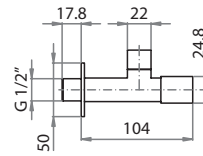

Imballo - Pack	1	QxC	10	QxB	200
Cod	1	10	200		

Cod

AL140.01	✓
----------	---

AL100

Rubinetto arresto sottolavabo cilindrico

- Materiale: ottone
 - Con filtro
 - 1/2" M x 1/2" M con snodo
 - Attacco tubetto ø 10 mm
- Brass angle valve with filter
- 1/2" male connection
 - Swivel joint
 - ø 10 mm inlet connection

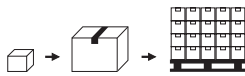
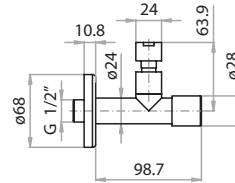

Imballo - Pack	1	QxC	10	QxB	200
Cod	1	10	200		

Cod	01	03	05	04	02	06	07	08	09	12	PVD Lucido Glossy	PVD Spazzolato Brushed
AL100._ _	✓		✓			✓				✓	✓	✓

AL90

Rubinetto arresto sottolavabo cilindrico

- Materiale: ottone
 - Con filtro
 - 1/2" M x 3/8" M
 - Attacco tubetto ø 10 mm
- Brass angle valve with filter
- 1/2" male connection
 - ø 10 mm inlet connection

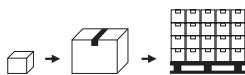
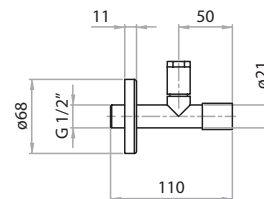

Imballo - Pack	1	QxC	10	QxB	200
Cod	1	10	200		

Cod

AL90.01	✓
---------	---



LINEA

Griglia in acciaio inox per canalina a pavimento
Stainless steel grid for linear drain



Imballo - Pack

Cod 1

Cod mm

GR01-6	600	✓
GR01-7	700	✓
GR01-8	800	✓
GR01-9	900	✓
GR01-10	1000	✓
GR01-12	1200	✓

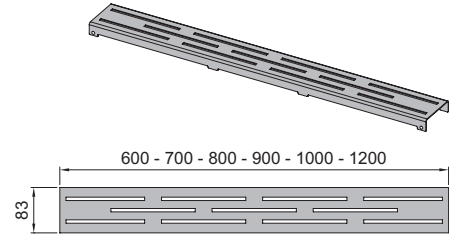

GRAFFITI

Griglia in acciaio inox per canalina a pavimento
Stainless steel grid for linear drain



Imballo - Pack

Cod 1

Cod mm

GR02-6	600	✓
GR02-7	700	✓
GR02-8	800	✓
GR02-9	900	✓
GR02-10	1000	✓
GR02-12	1200	✓

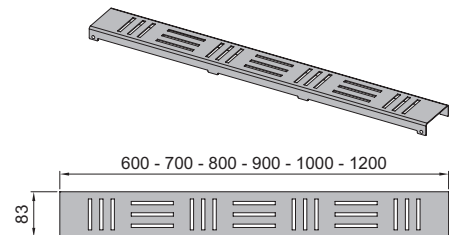

TESSERA

Griglia in acciaio inox per canalina a pavimento
Stainless steel grid for linear drain



Imballo - Pack

Cod 1

Cod mm

GR03-6	600	✓
GR03-7	700	✓
GR03-8	800	✓
GR03-9	900	✓
GR03-10	1000	✓
GR03-12	1200	✓

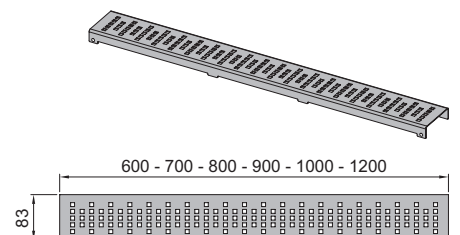

FUSION

Griglia in acciaio inox per canalina a pavimento
Stainless steel grid for linear drain



Imballo - Pack

Cod 1

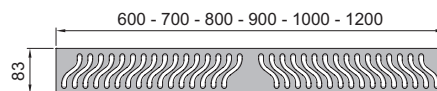
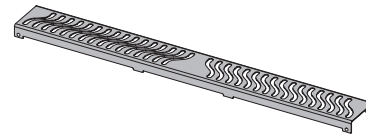

Cod mm

GR04-6	600	✓
GR04-7	700	✓
GR04-8	800	✓
GR04-9	900	✓
GR04-10	1000	✓
GR04-12	1200	✓

TILE

Griglia in acciaio inox **piastrellabile** per canalina a pavimento
Stainless steel tileable grid for linear drain



Imballo - Pack

Cod 1

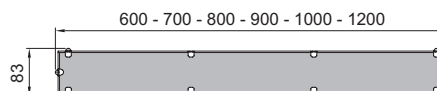
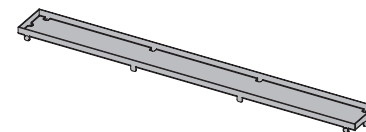

Cod mm

GR05-6	600	✓
GR05-7	700	✓
GR05-8	800	✓
GR05-9	900	✓
GR05-10	1000	✓
GR05-12	1200	✓

MINIMAL

Griglia in acciaio inox per canalina a pavimento
Stainless steel grid for linear drain



Imballo - Pack

Cod 1

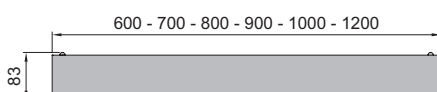
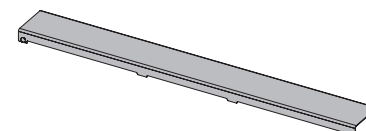

Cod mm

GR06-6	600	✓
GR06-7	700	✓
GR06-8	800	✓
GR06-9	900	✓
GR06-10	1000	✓
GR06-12	1200	✓

CDA

Canalina doccia in acciaio inox AISI 304 con sifone conforme alla normativa EN274

Altezza totale filo pavimento **105 mm**

Colonna d'acqua 50 mm

Portata di scarico 30 l/min.

AISI 304 stainless steel linear drain with swivel drain according to the EN274

Depth **105 mm** from finished floor surface

Hydraulic closure 50 mm

Flow rate 30 lt/min.



Imballo - Pack

Cod 1

Cod mm

CDA-7	700	✓
CDA-8	800	✓
CDA-9	900	✓
CDA-10	1000	✓
CDA-12	1200	✓

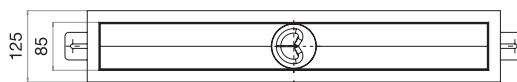
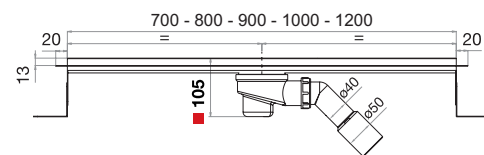

Kit canalina doccia + guaina isolante preformata + nastro butilico bi-adesivo

Linear shower drain kit + pre-sized isolation membrane + double-sided butyl tape

Cod mm

CDA-7GC	700	✓
CDA-8GC	800	✓
CDA-9GC	900	✓
CDA-10GC	1000	✓
CDA-12GC	1200	✓



CDB

Canalina doccia in acciaio inox AISI 304 con sifone ribassato

Altezza totale filo pavimento **85 mm**

Colonna d'acqua 30 mm

Portata di scarico 30 l/min.

AISI 304 stainless steel linear drain with low swivel drain

Depth **85 mm** from finished floor surface

Hydraulic closure 30 mm

Flow rate 30 lt/min



Imballo - Pack

Cod 1

Cod mm

CDB-7	700	✓
CDB-8	800	✓
CDB-9	900	✓
CDB-10	1000	✓
CDB-12	1200	✓

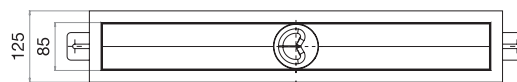
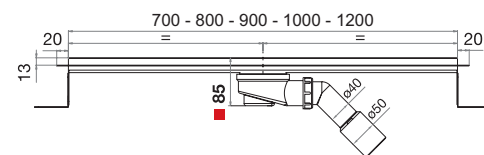

Kit canalina doccia + guaina isolante preformata + nastro butilico bi-adesivo

Linear shower drain kit + pre-sized isolation membrane + double-sided butyl tape

Cod mm

CDB-7GC	700	✓
CDB-8GC	800	✓
CDB-9GC	900	✓
CDB-10GC	1000	✓
CDB-12GC	1200	✓

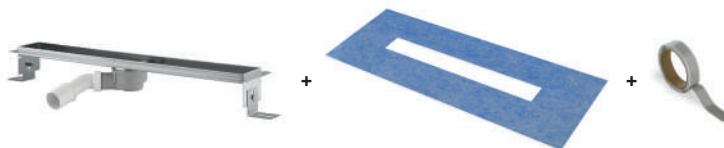

CDV

Canalina doccia in acciaio inox AISI 304 con sifone scarico verticale \varnothing 50 mm conforme alla normativa EN274

Colonna d'acqua 50 mm

Portata di scarico 60 l/min.

AISI 304 stainless steel linear drain with vertical drain \varnothing 50 mm according to the EN274

Hydraulic closure 50 mm

Flow rate 60 lt/min



Imballo - Pack

Cod 1

Cod mm

CDV-7	700	✓
CDV-8	800	✓
CDV-9	900	✓
CDV-10	1000	✓
CDV-12	1200	✓

Kit canalina doccia + guaina isolante preformata

+ nastro butilico bi-adesivo

Linear shower drain kit + pre-sized isolation membrane

+ double-sided butyl tape

Cod mm

CDV-7GC	700	✓
CDV-8GC	800	✓
CDV-9GC	900	✓
CDV-10GC	1000	✓
CDV-12GC	1200	✓

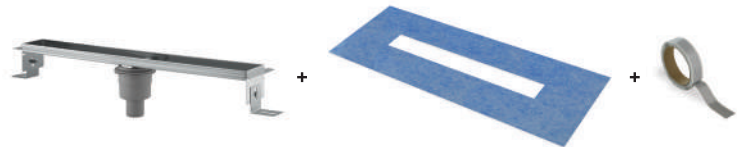
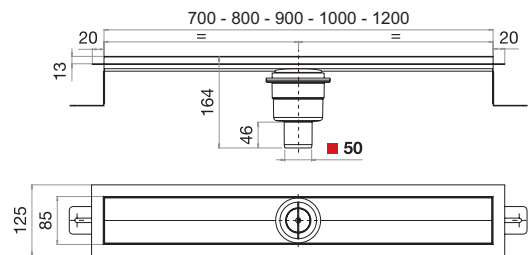

CDAP

Canalina doccia in polipropilene con sifone conforme alla normativa EN274

Altezza totale filo pavimento **105 mm**

Colonna d'acqua 50 mm

Portata di scarico 30 l/min.

Polypropylene linear drain with swivel drain according to the EN274

Depth **105 mm** from finished floor surface

Hydraulic closure 50 mm

Flow rate 30 lt/min.



Imballo - Pack

Cod 1

Cod mm

CDAP-6	600	✓
CDAP-7	700	✓
CDAP-8	800	✓
CDAP-9	900	✓

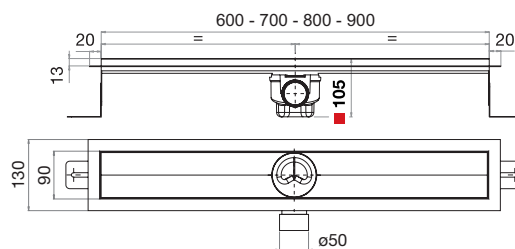

Kit canalina doccia + guaina isolante preformata

+ nastro butilico bi-adesivo

Linear shower drain kit + pre-sized isolation membrane

+ double-sided butyl tape

Cod mm

CDAP-6GC	600	✓
CDAP-7GC	700	✓
CDAP-8GC	800	✓
CDAP-9GC	900	✓



CDBP

Canalina doccia in polipropilene con sifone ribassato

Altezza totale filo pavimento **85 mm**

Colonna d'acqua 30 mm

Portata di scarico 30 l/min.

Polypropylene linear drain with low swivel drain

Depth **85 mm** from finished floor surface

Hydraulic closure 30 mm

Flow rate 30 lt/min



Imballo - Pack

Cod 1

Cod mm

CDBP-6	600	✓
CDBP-7	700	✓
CDBP-8	800	✓
CDBP-9	900	✓

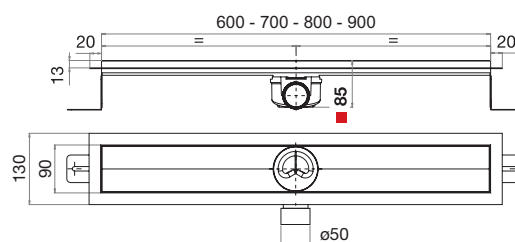

Kit canalina doccia + guaina isolante preformata

+ nastro butilico bi-adesivo

Linear shower drain kit + pre-sized isolation membrane

+ double-sided butyl tape

Cod mm

CDBP-6GC	600	✓
CDBP-7GC	700	✓
CDBP-8GC	800	✓
CDBP-9GC	900	✓



CDVP

Canalina doccia in polipropilene con sifone scarico verticale \varnothing 50 mm conforme alla normativa EN274

Colonna d'acqua 50 mm

Portata di scarico 60 l/min.

Polypropylene linear drain with vertical drain \varnothing 50 mm according to the EN274

Hydraulic closure 50 mm

Flow rate 60 lt/min



Imballo - Pack

Cod 1

Cod mm

CDVP-6	600	✓
CDVP-7	700	✓
CDVP-8	800	✓
CDVP-9	900	✓

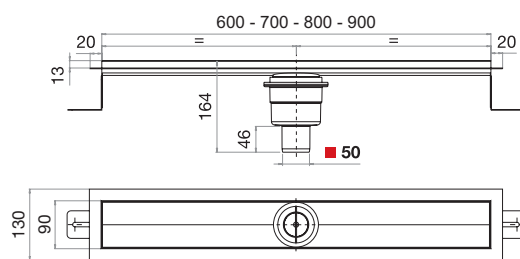

Kit canalina doccia + guaina isolante preformata

+ nastro butilico bi-adesivo

Linear shower drain kit + pre-sized isolation membrane

+ double-sided butyl tape

Cod mm

CDVP-6GC	600	✓
CDVP-7GC	700	✓
CDVP-8GC	800	✓
CDVP-9GC	900	✓



Guaina di isolamento preformata per canalina doccia
Pre-cut isolation membrane for linear drain

Cod	A x B mm	Riferimento Reference	
GUA-CD6	1100x420	600	✓
GUA-CD7	1100x420	700	✓
GUA-CD8	1230x420	800	✓
GUA-CD9	1410x420	900	✓
GUA-CD10	1410x420	1000	✓
GUA-CD12	1640x420	1200	✓

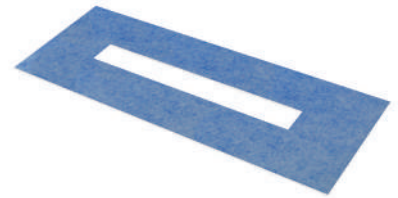
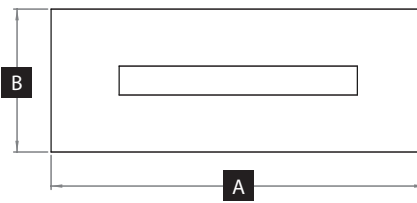

Guaina di isolamento in polietilene con doppio strato di tessuto-non tessuto
Isolation membrane in polyethylene with double layer fleece webbing

Cod	L cm	Rotolo Roll m	
ROG-100	12	10	✓
GUA-100	100	10	✓
GUA-300	100	30	✓

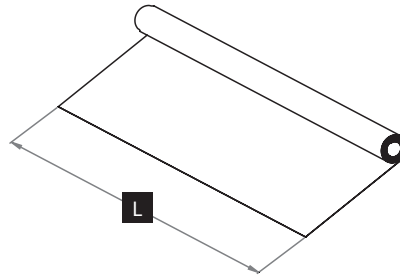

Angolo aperto preformato
Open pre-shaped corner

Cod	
ANG-E	✓

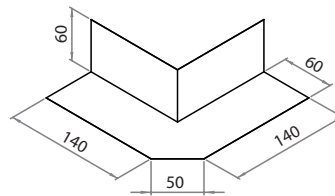

Angolo chiuso preformato
Closed pre-shaped corner

Cod	
ANG-I	✓

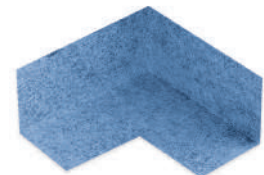
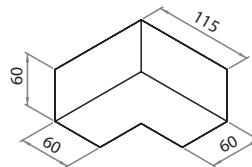

Nastro butilico bi-adesivo per fissaggio guaina su canalina doccia
Double-sided butyl tape for membrane application on linear drain

Cod	cm	
NAS-3	300x2	✓



Kit completo per montaggio modulare
Complete kit for modular assembly

Cod	
CD-R01	✓

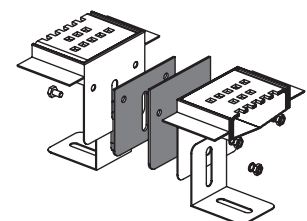



FD100.01G

Kit sifone di scarico a pavimento completamente ispezionabile
 + guaina isolante preformata 500x500 mm
 Griglia design 105x105 mm, spessore 5 mm
 Uscita laterale ø 50 mm
 Completely inspectable floor drain siphon kit
 Comes with pre-sized isolation membrane 500x500
 Design grid 105x105 mm, thickness 5 mm
 Side outlet ø 50 mm

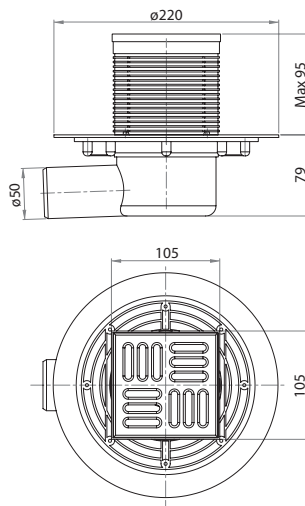



Imballo - Pack

Cod

1

Cod

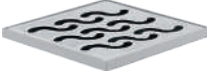
 "Grafitti"	FD100.01G	✓
 "Linea"	FD101.01G	✓
 "Fusion"	FD102.01G	✓

FD100.01

Sifone di scarico a pavimento completamente ispezionabile

Griglia design 105x105 mm, spessore 5 mm

Uscita laterale ø 50 mm

Completely inspectable floor drain siphon

Design grid 105x105 mm, thickness 5 mm

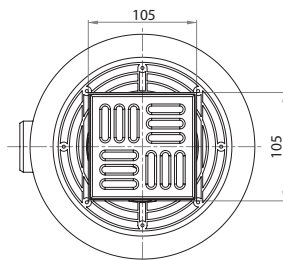
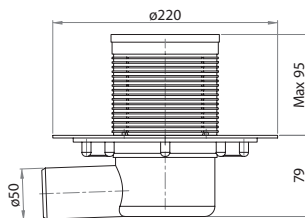

Imballo - Pack

Cod 1

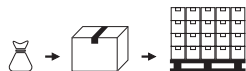

Imballo - Pack

FD100-AC

1

QxC

15

QxB

240

Cod

 "Graffiti"	FD100.01	✓
 "Linea"	FD101.01	✓
 "Fusion"	FD102.01	✓
 INOX	FD100-AC	✓





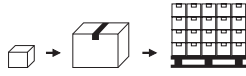
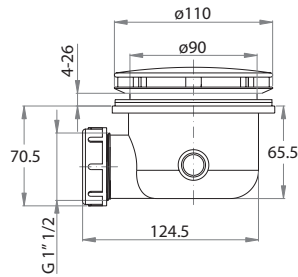





ST6590NV9

Sifone per piatto doccia foro \varnothing 90 mm, **sistema di fissaggio con viti inox**, tappo di copertura in ABS liscio
 Completamente ispezionabile
 Portata > 30 l/min conforme norma EN 274
 Shower tray siphon hole \varnothing 90 mm, **fixing system with inox screws**, ABS cover plug
 Completely inspectable trap
 Flow rate > 30 l/min according to EN 274 regulation

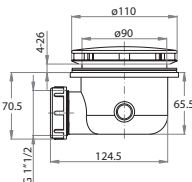

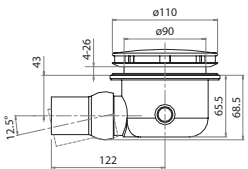
Imballo - Pack	QxC	QxB
Cod NV9	1 30	600
Cod NS4V9	1 30	600
Cod NS45V9	1 30	480
Cod NSV9	1 30	600

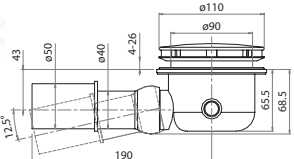

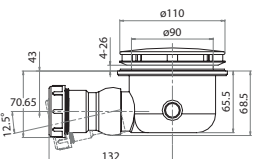
	Cod	 .01	 .33	 .43
  Terminale 1" 1/2 Outlet G 1" 1/2	ST6590._NV9	✓	✓	
  Terminale liscio \varnothing 40 a snodo Outlet \varnothing 40 with adjustable	ST6590._NS4V9	✓	✓	
  Terminale liscio \varnothing 40/50 a snodo Outlet \varnothing 40/50 with adjustable	ST6590._NS45V9	✓	✓	
  Terminale 1" 1/2 a snodo Outlet G 1" 1/2 with adjustable	ST6590._NSV9	✓	✓	

ST6590N

Sifone per piatto doccia foro \varnothing 90 mm con tappo di copertura in ABS liscio

Completamente ispezionabile

Portata > 30 l/min conforme norma EN 274







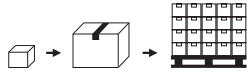
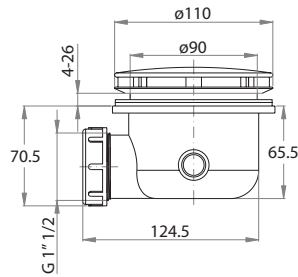



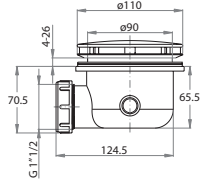

Shower tray siphon hole \varnothing 90 mm w/ABS cover plug

Completely inspectable trap

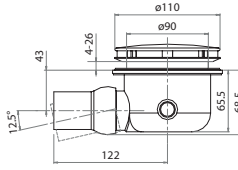
Flow rate > 30 l/min according to EN 274 regulation

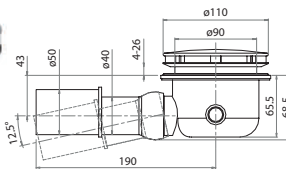

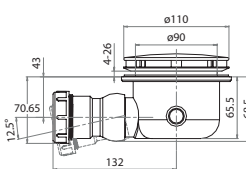
Imballo - Pack	QxC	QxB
Cod N	1 30	600
Cod NS4	1 30	600
Cod NS45	1 30	480
Cod NS	1 30	600
Cod NV	1 20	480

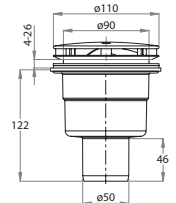
	Cod	 .01	 .33	 .43
  <p>Terminale 1" 1/2 Outlet G 1" 1/2</p>	ST6590.___N	✓	✓	
  <p>Terminale liscio \varnothing 40 a snodo Outlet \varnothing 40 with adjustable</p>	ST6590.___NS4	✓	✓	
  <p>Terminale liscio \varnothing 40/50 a snodo Outlet \varnothing 40/50 with adjustable</p>	ST6590.___NS45	✓	✓	
  <p>Terminale 1" 1/2 a snodo Outlet G 1" 1/2 with adjustable</p>	ST6590.___NS	✓	✓	
  <p>Scarico verticale \varnothing 50 Vertical drain \varnothing 50</p>	ST6590.___NV	✓	✓	



ST6590

Sifone per piatto doccia foro \varnothing 90 mm con terminale 1" 1/2 a snodo, tappo di copertura in ABS
 Completamente ispezionabile
 Portata > 30 l/min conforme norma EN 274
 Shower tray siphon hole \varnothing 90 mm with adjustable outlet terminal G 1" 1/2, ABS cover plug
 Completely inspectable trap
 Flow rate > 30 l/min according to EN 274 regulation

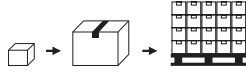
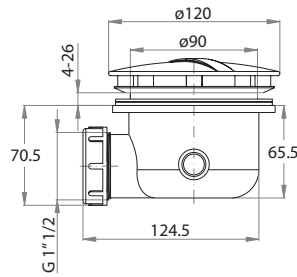

Imballo - Pack	QxC	QxB
Cod	1 30	600
Cod S4	1 30	600
Cod S45	1 30	480
Cod S	1 30	600
Cod V	1 20	480

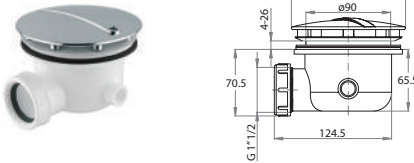
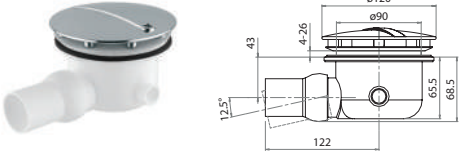
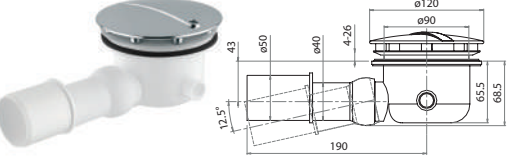
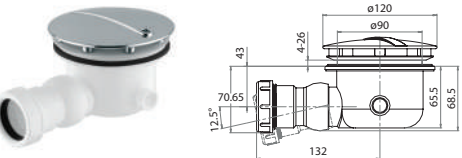
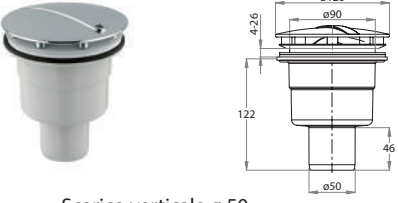
	Cod	
 <p>Terminale 1" 1/2 Outlet G 1" 1/2</p>	ST6590._ _	✓ ✓
 <p>Terminale liscio \varnothing 40 a snodo Outlet \varnothing 40 with adjustable</p>	ST6590._ _S4	✓ ✓
 <p>Terminale liscio \varnothing 40/50 a snodo Outlet \varnothing 40/50 with adjustable</p>	ST6590._ _S45	✓ ✓
 <p>Terminale 1" 1/2 a snodo Outlet G 1" 1/2 with adjustable</p>	ST6590._ _S	✓ ✓
 <p>Scarico verticale \varnothing 50 Vertical drain \varnothing 50</p>	ST6590._ _V	✓ ✓

ST6590A

Sifone per piatto doccia foro \varnothing 90 mm senza tappo di copertura

Completamente ispezionabile

Portata > 30 l/min conforme norma EN 274

Shower tray siphon hole \varnothing 90 mm without cover plug

Completely inspectable trap

Flow rate > 30 l/min according to EN 274 regulation

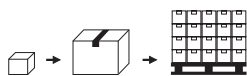
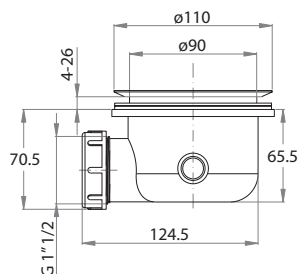

Imballo - Pack		QxC	QxB
Cod A	1	30	600
Cod AS4	1	30	600
Cod AS45	1	30	480
Cod AS	1	30	600
Cod AV	1	20	480

Cod

<p>Terminale 1" 1/2 Outlet G 1" 1/2</p>	<p>ST6590A</p>	<p>✓</p>
<p>Terminale liscio \varnothing 40 a snodo Outlet \varnothing 40 with adjustable</p>	<p>ST6590AS4</p>	<p>✓</p>
<p>Terminale liscio \varnothing 40/50 a snodo Outlet \varnothing 40/50 with adjustable</p>	<p>ST6590AS45</p>	<p>✓</p>
<p>Terminale 1" 1/2 a snodo Outlet G 1" 1/2 with adjustable</p>	<p>ST6590AS</p>	<p>✓</p>
<p>Scarico verticale \varnothing 50 Vertical drain \varnothing 50</p>	<p>ST6590AV</p>	<p>✓</p>

ST7250

Sifone per piatto doccia foro \varnothing 50-60 mm con tappo di copertura in ABS cromo
 Ispezionabile
 Shower tray siphon hole \varnothing 50-60 mm w/ABS chrome cover plug
 Inspectable trap

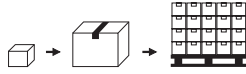
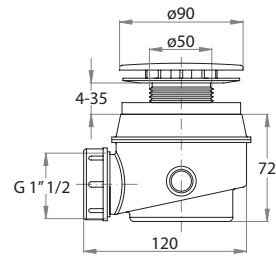

Imballo - Pack	QxC	QxB
Cod	1	30
		840

Cod	.01	.35
ST7250._ _	✓	
ST7250._ _		✓

ST7250-AC

Sifone per piatto doccia foro \varnothing 50-60 mm con tappo di copertura in inox
 Ispezionabile
 Shower tray siphon hole \varnothing 50-60 mm w/inox cover plug
 Inspectable trap

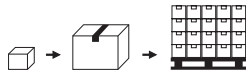
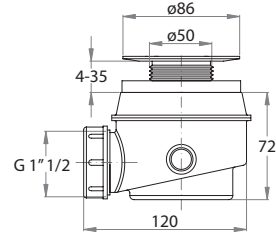

Imballo - Pack	QxC	QxB
Cod	1	30
		840

ST7250-AC	✓
-----------	---

ST7660

Sifone per piatto doccia foro \varnothing 60 mm con tappo di copertura in ABS cromo
 Completamente ispezionabile
 Shower tray siphon hole \varnothing 60 mm w/ABS chrome cover plug
 Completely inspectable trap

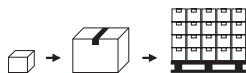
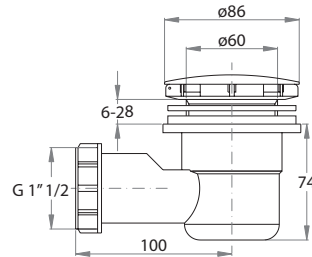

Imballo - Pack	QxC	QxB
Cod	1	30
		600

Cod	.01	.35
ST7660._ _	✓	
ST7660._ _		✓



048-CT

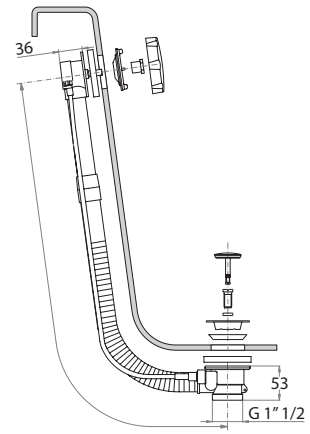

Colonna di scarico per vasca in ottone/rame
 • Disponibile per vasche normali e a sedile
 Bath pop-up waste & overflow in brass/copper
 • Available for standard bathtubs and chair bathtubs

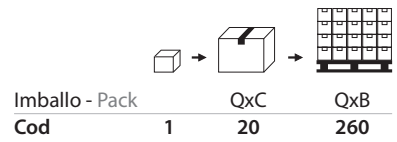

	Cod	L cm	.01	.16	.33 .35 .43	.25 .26 .38 .40	.12	PVD Lucido Glossy	PVD Spazzolato Brushed
	048-CT._._	45-55	✓	✓	✓	✓	✓	✓	✓
	048-CT-1._._	56-65	✓	✓	✓	✓	✓	✓	✓
	048-CT-A._._	45-55	✓		✓	✓	✓		
	048-CT-A-1._._	56-65	✓		✓	✓	✓		
	048-CT-L._._	45-55	✓	✓	✓	✓	✓	✓	✓
	048-CT-L-1._._	56-65	✓	✓	✓	✓	✓	✓	✓
	048-CT-M._._	45-55	✓	✓	✓	✓	✓	✓	✓
	048-CT-M-1._._	56-65	✓	✓	✓	✓	✓	✓	✓
	048-CT-MA._._	45-55	✓		✓	✓	✓		
	048-CT-MA-1._._	56-65	✓		✓	✓	✓		
	048-CT-PLUS._._	45-55	✓	✓	✓	✓	✓	✓	✓
	048-CT-PLUS-1._._	56-65	✓	✓	✓	✓	✓	✓	✓

48-CT

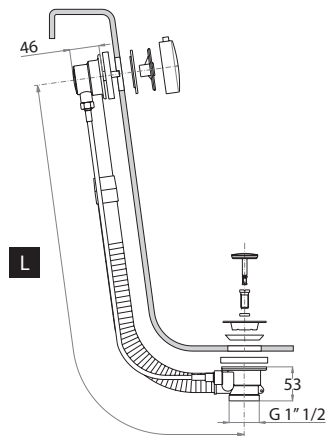

Colonna di scarico per vasca in ottone/rame
Bath pop-up waste & overflow in brass/copper

Imballo - Pack	1	QxC	QxB
Cod-1	1	20	260
Cod-2, Cod-3	1	12	120

		Cod	L cm	.01	.16	.33 .35 .43	.25 .26 .38 .40	.12	PVD Lucido Glossy	PVD Spazzolato Brushed
6 Grooves ø 42 Brass	48-CT._._	45-55	✓	✓	✓	✓	✓	✓	✓	✓
	48-CT-1._._	56-65	✓	✓	✓	✓	✓	✓	✓	✓
	48-CT-2._._	70-80	✓	✓	✓	✓	✓	✓	✓	✓
	48-CT-3._._	81-90	✓	✓	✓	✓	✓	✓	✓	✓
6 Grooves ø 72 ABS	48-CT-A._._	45-55	✓		✓	✓	✓	✓		
	48-CT-A-1._._	56-65	✓		✓	✓	✓	✓		
	48-CT-A-2._._	70-80	✓		✓	✓	✓	✓		
	48-CT-A-3._._	81-90	✓		✓	✓	✓	✓		
6 Grooves ø 72 Brass	48-CT-L._._	45-55	✓	✓	✓	✓	✓	✓	✓	✓
	48-CT-L-1._._	56-65	✓	✓	✓	✓	✓	✓	✓	✓
	48-CT-L-2._._	70-80	✓	✓	✓	✓	✓	✓	✓	✓
	48-CT-L-3._._	81-90	✓	✓	✓	✓	✓	✓	✓	✓
Minimal ø 42 Brass	48-CT-M._._	45-55	✓	✓	✓	✓	✓	✓	✓	✓
	48-CT-M-1._._	56-65	✓	✓	✓	✓	✓	✓	✓	✓
	48-CT-M-2._._	70-80	✓	✓	✓	✓	✓	✓	✓	✓
	48-CT-M-3._._	81-90	✓	✓	✓	✓	✓	✓	✓	✓
Minimal ø 72 ABS	48-CT-MA._._	45-55	✓		✓	✓	✓	✓		
	48-CT-MA-1._._	56-65	✓		✓	✓	✓	✓		
	48-CT-MA-2._._	70-80	✓		✓	✓	✓	✓		
	48-CT-MA-3._._	81-90	✓		✓	✓	✓	✓		
Minimal ø 72 Brass	48-CT-PLUS._._	45-55	✓	✓	✓	✓	✓	✓	✓	✓
	48-CT-PLUS-1._._	56-65	✓	✓	✓	✓	✓	✓	✓	✓
	48-CT-PLUS-2._._	70-80	✓	✓	✓	✓	✓	✓	✓	✓
	48-CT-PLUS-3._._	81-90	✓	✓	✓	✓	✓	✓	✓	✓

Differenti lunghezze fino a 125 cm
Lengths available up to 125 cm

Metallo Brass

101

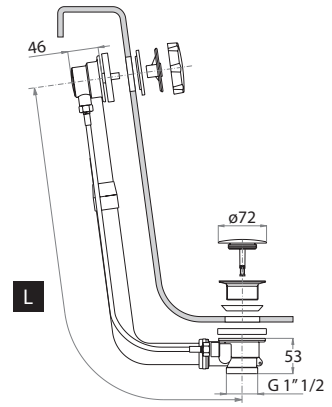

Colonna di scarico per vasca interamente in ottone
 • Trasmissione con movimento "Eccentric"
 Bath pop-up waste & overflow entirely in brass
 • "Eccentric" drive system



Imballo - Pack	1	QxC	QxB
Cod	1	20	260

	Cod	L cm	ø .01	ø .16	ø .33	ø .35	ø .43	ø .25	ø .26	ø .38	ø .40	ø .12	PVD Lucido Glossy	PVD Spazzolato Brushed
 6 Grooves ø 42 Brass	101-__	45-55	✓	✓	✓				✓			✓	✓	✓
	101-1-__	56-65	✓	✓	✓				✓			✓	✓	✓
 6 Grooves ø 72 ABS	101-A-__	45-55	✓		✓				✓			✓		
	101-A-1-__	56-65	✓		✓				✓			✓		
 6 Grooves ø 72 Brass	101-L-__	45-55	✓	✓	✓				✓			✓	✓	✓
	101-L-1-__	56-65	✓	✓	✓				✓			✓	✓	✓
 Minimal ø 42 Brass	101-M-__	45-55	✓	✓	✓				✓			✓	✓	✓
	101-M-1-__	56-65	✓	✓	✓				✓			✓	✓	✓
 Minimal ø 72 ABS	101-MA-__	45-55	✓		✓				✓			✓		
	101-MA-1-__	56-65	✓		✓				✓			✓		
 Minimal ø 72 Brass	101-PLUS-__	45-55	✓	✓	✓				✓			✓	✓	✓
	101-PLUS-1-__	56-65	✓	✓	✓				✓			✓	✓	✓

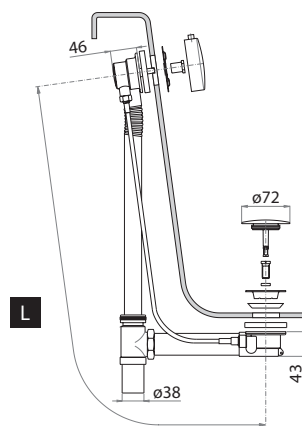
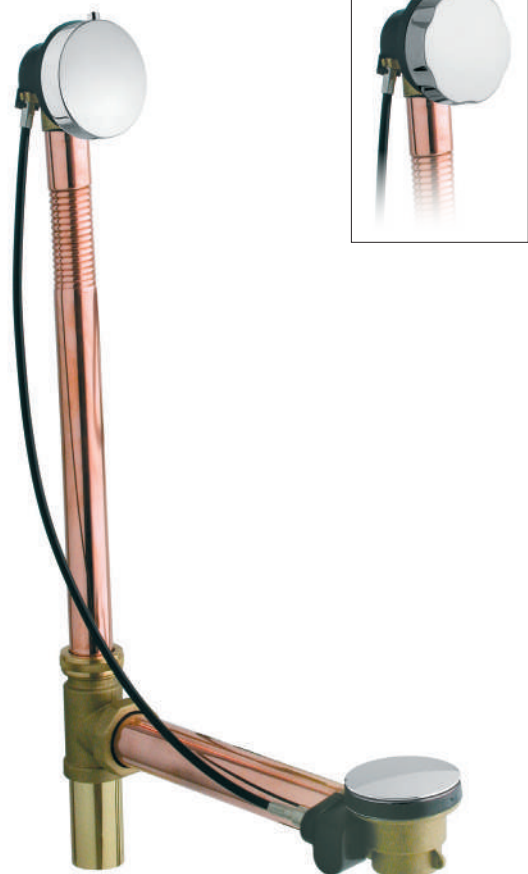

Colonna di scarico per vasca modello "America"
 • Trasmissione con movimento "Direct"
 Bath pop-up waste & overflow "America" model
 • "Direct" drive system

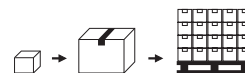

Imballo - Pack	QxC	QxB
Cod-1	1 20	260
Cod-2, Cod-3	1 12	120

Cod	L cm	Color										PVD Lucido Glossy	PVD Spazzolato Brushed
		.01	.16	.33	.35	.43	.25	.26	.38	.40	.12		
	108-1._._	45-65	✓	✓	✓		✓				✓	✓	✓
	108-2._._	70-80	✓	✓	✓		✓			✓	✓	✓	✓
	108-3._._	81-90	✓	✓	✓		✓			✓	✓	✓	✓
	108-A-1._._	45-65	✓		✓		✓			✓			
	108-A-2._._	70-80	✓		✓		✓			✓			
	108-A-3._._	81-90	✓		✓		✓			✓			
	108-L-1._._	45-65	✓	✓	✓		✓			✓	✓	✓	✓
	108-L-2._._	70-80	✓	✓	✓		✓			✓	✓	✓	✓
	108-L-3._._	81-90	✓	✓	✓		✓			✓	✓	✓	✓
	108-M-1._._	45-65	✓	✓	✓		✓			✓	✓	✓	✓
	108-M-2._._	70-80	✓	✓	✓		✓			✓	✓	✓	✓
	108-M-3._._	81-90	✓	✓	✓		✓			✓	✓	✓	✓
	108-MA-1._._	45-65	✓		✓		✓			✓			
	108-MA-2._._	70-80	✓		✓		✓			✓			
	108-MA-3._._	81-90	✓		✓		✓			✓			
	108-PLUS-1._._	45-65	✓	✓	✓		✓			✓	✓	✓	✓
	108-PLUS-2._._	70-80	✓	✓	✓		✓			✓	✓	✓	✓
	108-PLUS-3._._	81-90	✓	✓	✓		✓			✓	✓	✓	✓

SK048

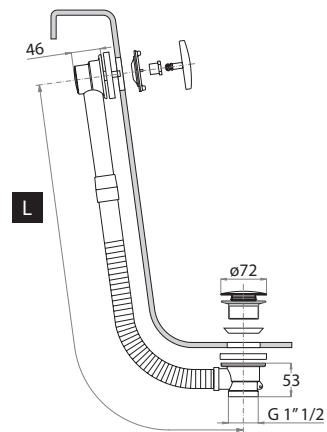

Colonna di scarico per vasca in ottone/rame
Bath "Skip-up" waste & overflow in brass/
copper

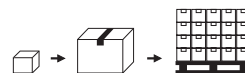

Imballo - Pack	QxC	QxB
Cod, Cod-1	1	20
Cod-2, Cod-3	1	12

	Cod	L cm	Color											PVD Lucido Glossy	PVD Spazzolato Brushed
			ø72 Brass	.01	.16	.33	.35	.43	.25	.26	.38	.40	.12		
ø72 Brass	SK048._._	45-55	✓	✓		✓				✓		✓	✓	✓	
	SK048-1._._	56-65	✓	✓		✓				✓		✓	✓	✓	
	SK048-2._._	70-80	✓	✓		✓				✓		✓	✓	✓	
	SK048-3._._	81-90	✓	✓		✓				✓		✓	✓	✓	
ø72 ABS	SK048-A._._	45-55	✓			✓				✓		✓			
	SK048-A-1._._	56-65	✓			✓				✓		✓			
	SK048-A-2._._	70-80	✓			✓				✓		✓			
	SK048-A-3._._	81-90	✓			✓				✓		✓			



TK104 **NF**

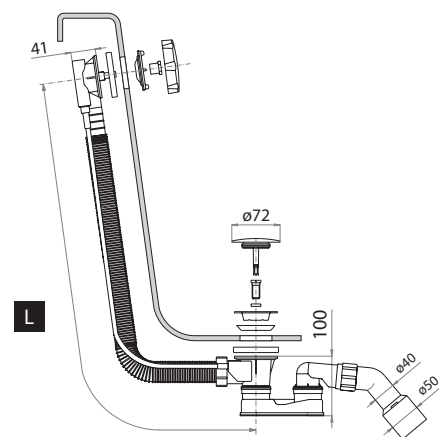

Colonna di scarico per vasca in polipropilene completa di sifone ribassato preassemblato
 Bath pop-up waste & overflow in polypropylene complete with pre-assembled low siphon

Vasca Bathtub

Imballo - Pack	1	QxC	12	QxB	216
Cod					

Cod	L cm	.01	.16	.33 .35 .43			.25 .26 .38 .40				.12	PVD Lucido Glossy	PVD Spazzolato Brushed
 6 Grooves ø 42 Brass	TK104.__ 45-55	✓	✓	✓			✓			✓	✓	✓	
	TK104-1.__ 56-65	✓	✓	✓			✓			✓	✓	✓	
 6 Grooves ø 72 ABS	TK104-A.__ 45-55	✓		✓			✓			✓			
	TK104-A-1.__ 56-65	✓		✓			✓			✓			
 6 Grooves ø 72 Brass	TK104-L.__ 45-55	✓	✓	✓			✓			✓	✓	✓	
	TK104-L-1.__ 56-65	✓	✓	✓			✓			✓	✓	✓	
 Minimal ø 42 Brass	TK104-M.__ 45-55	✓	✓	✓			✓			✓	✓	✓	
	TK104-M-1.__ 56-65	✓	✓	✓			✓			✓	✓	✓	
 Minimal ø 72 ABS	TK104-MA.__ 45-55	✓		✓			✓			✓			
	TK104-MA-1.__ 56-65	✓		✓			✓			✓			
 Minimal ø 72 Brass	TK104-PLUS.__ 45-55	✓	✓	✓			✓			✓	✓	✓	
	TK104-PLUS-1.__ 56-65	✓	✓	✓			✓			✓	✓	✓	

Per opzioni vedere risvolto di copertina
 For options check the cover flap

Plastica Plastic

Differenti lunghezze fino a 125 cm
 Lengths available up to 125 cm

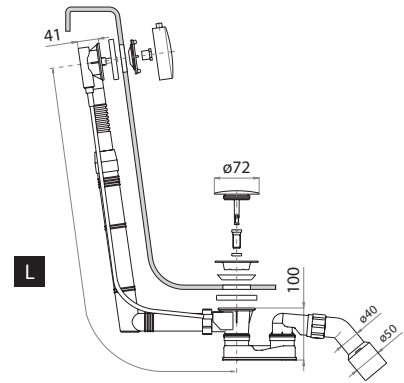

Colonna di scarico per vasca in polipropilene completa di sifone ribassato preassemblato
 Bath pop-up waste & overflow in polypropylene complete with pre-assembled low siphon

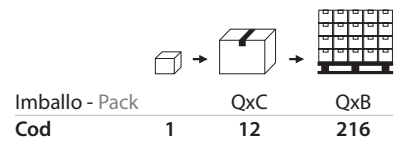

	L										PVD Lucido Glossy	PVD Spazzolato Brushed
Cod	cm	.01	.16	.33	.35	.43	.25	.26	.38	.40	.12	
 6 Grooves ø 42 Brass	TK106.____	45-55	✓	✓	✓		✓				✓	✓
	TK106-1.____	56-65	✓	✓	✓		✓				✓	✓
 6 Grooves ø 72 ABS	TK106-A.____	45-55	✓		✓		✓				✓	
	TK106-A-1.____	56-65	✓		✓		✓				✓	
 6 Grooves ø 72 Brass	TK106-L.____	45-55	✓	✓	✓		✓				✓	✓
	TK106-L-1.____	56-65	✓	✓	✓		✓				✓	✓
 Minimal ø 42 Brass	TK106-M.____	45-55	✓	✓	✓		✓				✓	✓
	TK106-M-1.____	56-65	✓	✓	✓		✓				✓	✓
 Minimal ø 72 ABS	TK106-MA.____	45-55	✓		✓		✓				✓	
	TK106-MA-1.____	56-65	✓		✓		✓				✓	
 Minimal ø 72 Brass	TK106-PLUS.____	45-55	✓	✓	✓		✓				✓	✓
	TK106-PLUS-1.____	56-65	✓	✓	✓		✓				✓	✓

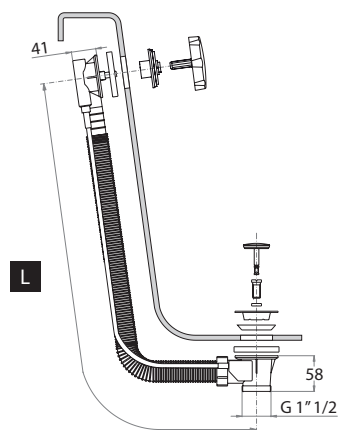

Colonna di scarico per vasca in polipropilene

- Tubo di troppo pieno flessibile
- Maniglia con fissaggio a scatto

Bath pop-up waste & overflow in polypropylene

- Flexible overflow pipe
- Handle with "Snap-in" fixing system

Option

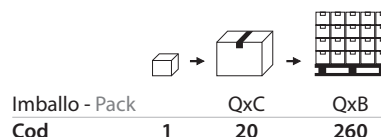

Imballo - Pack

Cod

1

QxC

20

QxB

260

	Cod	L cm	.01	.33 .35 .43	.25 .26 .38 .40	.12
6 Grooves ABS ø 42 Brass	140.__	45-55	✓	✓	✓	✓
	140-1.__	56-65	✓	✓	✓	✓
	140-2.__	70-80	✓	✓	✓	✓
	140-3.__	81-90	✓	✓	✓	✓
6 Grooves ABS ø 72 ABS	140-A.__	45-55	✓	✓	✓	✓
	140-A-1.__	56-65	✓	✓	✓	✓
	140-A-2.__	70-80	✓	✓	✓	✓
	140-A-3.__	81-90	✓	✓	✓	✓
Minimal ABS ø 42 Brass	140-M.__	45-55	✓	✓	✓	✓
	140-M-1.__	56-65	✓	✓	✓	✓
	140-M-2.__	70-80	✓	✓	✓	✓
	140-M-3.__	81-90	✓	✓	✓	✓
Minimal ABS ø 72 ABS	140-PLUS.__	45-55	✓	✓	✓	✓
	140-PLUS-1.__	56-65	✓	✓	✓	✓
	140-PLUS-2.__	70-80	✓	✓	✓	✓
	140-PLUS-3.__	81-90	✓	✓	✓	✓

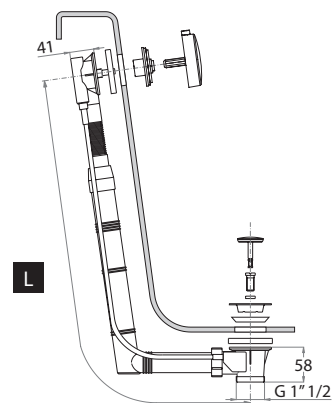

Colonna di scarico per vasca in polipropilene

- Tubo di troppo pieno "Flex-top"
- Maniglia con fissaggio a scatto

Bath pop-up waste & overflow in polypropylene

- "Flex-top" overflow pipe
- Handle with "Snap-in" fixing system

Option

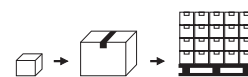

Imballo - Pack	1	QxC	QxB
Cod	1	20	260

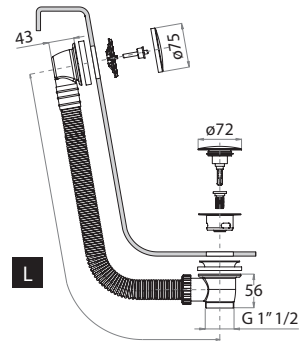

		L									
	Cod	cm	.01	.33	.35	.43	.25	.26	.38	.40	.12
	160. __	45-55	✓		✓			✓			✓
	160-1. __	56-65	✓		✓			✓			✓
	160-2. __	70-80	✓		✓			✓			✓
	160-3. __	81-90	✓		✓			✓			✓
	160-A. __	45-55	✓		✓			✓			✓
	160-A-1. __	56-65	✓		✓			✓			✓
	160-A-2. __	70-80	✓		✓			✓			✓
	160-A-3. __	81-90	✓		✓			✓			✓
	160-M. __	45-55	✓		✓			✓			✓
	160-M-1. __	56-65	✓		✓			✓			✓
	160-M-2. __	70-80	✓		✓			✓			✓
	160-M-3. __	81-90	✓		✓			✓			✓
	160-PLUS. __	45-55	✓		✓			✓			✓
	160-PLUS-1. __	56-65	✓		✓			✓			✓
	160-PLUS-2. __	70-80	✓		✓			✓			✓
	160-PLUS-3. __	81-90	✓		✓			✓			✓

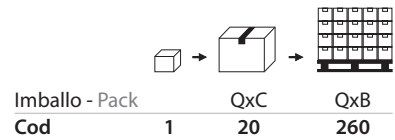

- Colonna di scarico per vasca in polipropilene
- Sistema di comando "Skip-up" con "QuikFix"
 - Tubo di troppo pieno flessibile
- Bath "Skip-up" waste & overflow in polypropylene
- "Skip-up" plug with "QuikFix" system
 - Flexible overflow pipe

Option



	Cod	L cm	.01	.16	.33 .35 .43	.25 .26 .38 .40	.12	PVD Lucido Glossy	PVD Spazzolato Brushed
 ø 72 Brass	SK14._ _	45-80	✓	✓	✓	✓	✓	✓	✓
	SK14-1._ _	81-125	✓	✓	✓	✓	✓	✓	✓
 ø 72 ABS	SK14-A._ _	45-80	✓		✓	✓	✓		
	SK14-A-1._ _	81-125	✓		✓	✓	✓		

SK16

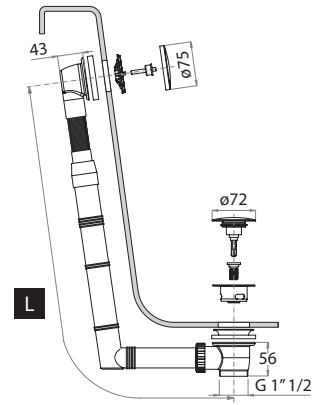

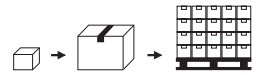

- Colonna di scarico per vasca in polipropilene
- Sistema di comando "Skip-up" con "QuikFix"
 - Tubo di troppo pieno "Flex-top"
- Bath "Skip-up" waste & overflow in polypropylene
- "Skip-up" plug with "QuikFix" system
 - "Flex-top" overflow pipe

Option



Imballo - Pack		QxC	QxB
Cod	1	20	260

	Cod	L cm	.01	.16	.33 .35 .43	.25 .26 .38 .40	.12	PVD Lucido Glossy	PVD Spazzolato Brushed
	SK16._._	45-65	✓	✓	✓	✓	✓	✓	✓
	SK16-A._._	45-65	✓		✓	✓	✓		

SK14-INOX • TSK14-INOX



- Colonna di scarico per vasca in polipropilene
- Copertura di troppo pieno e tappo ø 72 mm in acciaio inox AISI 316L
 - Sistema di comando "Skip-up"
 - Tubo di troppo pieno flessibile
- Bath "Skip-up" waste & overflow in polypropylene
- AISI 316L stainless steel overflow cover and plug ø 72 mm
 - "Skip-up" plug system
 - Flexible overflow pipe

Option

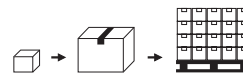

Imballo - Pack	QxC	QxB	
Cod	1	12	216



	Cod	L cm	
	SK14-INOX	45-125	✓
	TSK14-INOX	45-125	✓

140-PL-INOX • TK140-PL-INOX



- Colonna di scarico per vasca in polipropilene
- Copertura di troppo pieno e tappo ø 72 mm in acciaio inox AISI 316L
- Tubo di troppo pieno flessibile
- Bath waste & overflow in polypropylene
- AISI 316L stainless steel overflow cover and plug ø 72 mm
- Flexible overflow pipe

Option

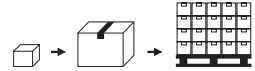

Imballo - Pack	1	QxC	12	QxB	216
Cod	1	12	216		



	Cod	L cm	
	140-PL-INOX	45-55	✓
	140-PL-1-INOX	56-65	✓
	140-PL-2-INOX	70-80	✓
	140-PL-3-INOX	81-90	✓
	TK140-PL-INOX	45-55	✓
	TK140-PL-1-INOX	56-65	✓
	TK140-PL-2-INOX	70-80	✓
	TK140-PL-3-INOX	81-90	✓

SK20+64-B

Scarico per vasca con troppo pieno integrato

- Tappo ottone ø 72 mm con meccanismo a pressione "Skip-up 2.0", sistema "QuikFix"
 - Sifone in polipropilene ribassato 1" 1/2
- Bath waste & overflow with integrated overflow
- "QuikFix" system ø 72 mm "Skip-up 2.0" brass plug
 - 1" 1/2 low siphon in polypropylene

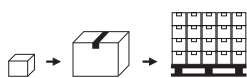

Imballo - Pack	1	QxC	QxB
Cod	1	30	600

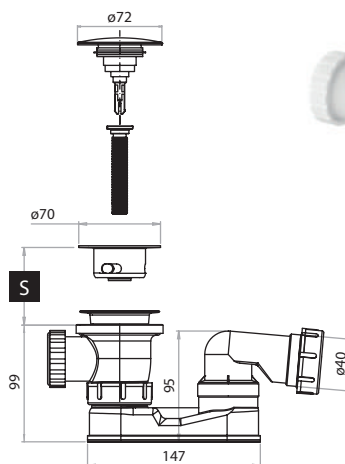

NEW

Cod	S	mm										PVD Lucido Glossy	PVD Spazzolato Brushed
		.01	.16	.33	.35	.43	.25	.26	.38	.40	.12		
SK20._.+64-B	0-70	✓	✓	✓	✓	✓	✓	✓	✓	✓	✓	✓	✓

SK20-INOX

Scarico per vasca con troppo pieno integrato

- Tappo acciaio INOX ø 72 mm con meccanismo a pressione "Skip-up 2.0", sistema "QuikFix"
- Bath waste & overflow with integrated overflow
- "QuikFix" system ø 72 mm "Skip-up 2.0" stainless steel plug



Imballo - Pack	1	QxC	QxB
Cod	1	30	600

INOX
AISI 316L

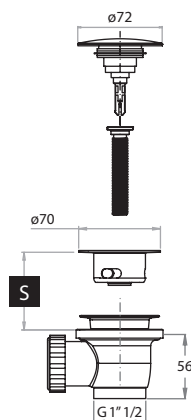

NEW

Cod	S	mm											
		.01	.16	.33	.35	.43	.25	.26	.38	.40	.12		
SK20-INOX	0-70	✓											

SKN22

Scarico per vasca con troppo pieno integrato

- Tappo ottone ø 72 mm con meccanismo a pressione "Skip-up 2.0", sistema "QuikFix"
- Bath waste & overflow with integrated overflow
- "QuikFix" system ø 72 mm "Skip-up 2.0" brass plug

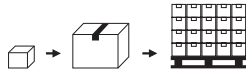

Imballo - Pack	1	QxC	30	QxB	600
Cod					

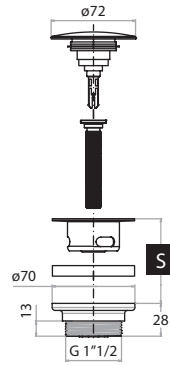

Cod	S	mm	Color				PVD						
			.01	.33	.35	.43	.25	.26	.38	.40	.12	Lucido Glossy	Spazzolato Brushed
SKN22._ _		15-50	✓		✓				✓			✓	

SKN22+64-B

Scarico per vasca con troppo pieno integrato

- Tappo ottone ø 72 mm con meccanismo a pressione "Skip-up 2.0", sistema "QuikFix"
- Sifone in polipropilene ribassato 1" 1/2
- Bath waste & overflow with integrated overflow
- "QuikFix" system ø 72 mm "Skip-up 2.0" brass plug
- 1" 1/2 low siphon in polypropylene

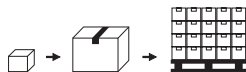

Imballo - Pack	1	QxC	30	QxB	600
Cod					

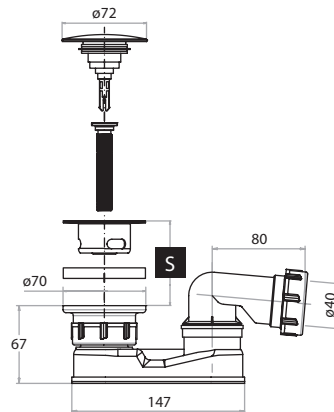

Cod	S	mm	Color				PVD						
			.01	.33	.35	.43	.25	.26	.38	.40	.12	Lucido Glossy	Spazzolato Brushed
SKN22._ _+64-B		15-50	✓		✓			✓			✓		✓

Colonna di scarico per vasca in polipropilene serie UNIKA

- Maniglia con frizione di protezione movimento
- Tappo ø 72 mm in ABS, filtro ispezionabile
- Intercambiabilità con sistema di comando a pressione "Skip-up"

Bath pop-up waste & overflow in polypropylene UNIKA series

- Control knob with special clutch system to protect movement
- Plug ø 72 mm in ABS, removable filter
- Plug is interchangeable with "Skip-up" style plug

Option

TK

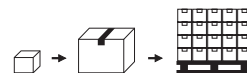

Imballo - Pack	1	QxC	QxB
Cod	1	10	130



	Cod	L cm	
	UK-04.01	45-55	✓
	UK-04-1.01	56-65	✓
	UK-04-2.01	70-80	✓
	UK-04-3.01	81-90	✓
	UTK-04.01	45-55	✓
	UTK-04-1.01	56-65	✓
	UTK-04-2.01	70-80	✓
	UTK-04-3.01	81-90	✓



Colonna di scarico per vasca in polipropilene serie UNIKA

- Maniglia con frizione di protezione movimento
- Tappo ø 72 mm in ABS, filtro ispezionabile
- Intercambiabilità con sistema di comando a pressione "Skip-up"

• **Tubo di troppo pieno "Flex-top"**

Bath pop-up waste & overflow in polypropylene UNIKA series



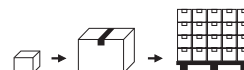

- Control knob with special clutch system to protect movement
- Plug ø 72 mm in ABS, removable filter
- Plug is interchangeable with "Skip-up" style plug
- **"Flex-top" overflow pipe**

Option

TK

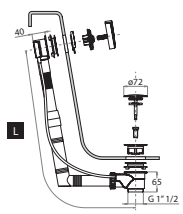

Imballo - Pack	QxC	QxB
Cod 1	10	130

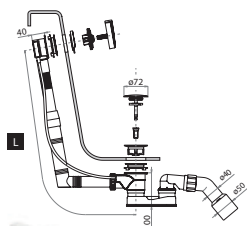
	Cod	 cm	
 	UK-06.01	45-55	✓
	UK-06-1.01	56-65	✓
 	UTK-06.01	45-55	✓
	UTK-06-1.01	56-65	✓



130-CT

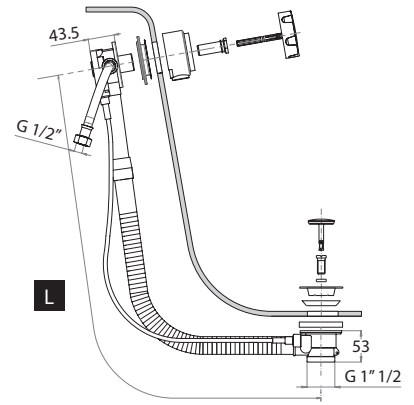

Colonna di scarico per vasca in ottone/rame
 • Trasmissione con movimento a cremagliera
 Bath pop-up waste & overflow in brass/copper
 • Rack and pinion drive system



Imballo - Pack	1	QxC	10	QxB	260
Cod					

		Cod	L cm	.01	.16	.33	.35	.43	.25	.26	.38	.40	.12	PVD Lucido Glossy	PVD Spazzolato Brushed
6 Grooves ø 42 Brass		130-CT._._	45-55	✓	✓	✓			✓				✓	✓	✓
		130-CT-1._._	56-65	✓	✓	✓			✓				✓	✓	✓
		130-CT-2._._	70-80	✓	✓	✓			✓				✓	✓	✓
		130-CT-3._._	81-90	✓	✓	✓			✓				✓	✓	✓
6 Grooves ø 72 ABS		130-CT-A._._	45-55	✓		✓			✓				✓		
		130-CT-A-1._._	56-65	✓		✓			✓				✓		
		130-CT-A-2._._	70-80	✓		✓			✓				✓		
		130-CT-A-3._._	81-90	✓		✓			✓				✓		
6 Grooves ø 72 Brass		130-CT-L._._	45-55	✓	✓	✓			✓				✓	✓	✓
		130-CT-L-1._._	56-65	✓	✓	✓			✓				✓	✓	✓
		130-CT-L-2._._	70-80	✓	✓	✓			✓				✓	✓	✓
		130-CT-L-3._._	81-90	✓	✓	✓			✓				✓	✓	✓
Minimal ø 42 Brass		130-CT-M._._	45-55	✓	✓	✓			✓				✓	✓	✓
		130-CT-M-1._._	56-65	✓	✓	✓			✓				✓	✓	✓
		130-CT-M-2._._	70-80	✓	✓	✓			✓				✓	✓	✓
		130-CT-M-3._._	81-90	✓	✓	✓			✓				✓	✓	✓
Minimal ø 72 ABS		130-CT-MA._._	45-55	✓		✓			✓				✓		
		130-CT-MA-1._._	56-65	✓		✓			✓				✓		
		130-CT-MA-2._._	70-80	✓		✓			✓				✓		
		130-CT-MA-3._._	81-90	✓		✓			✓				✓		
Minimal ø 72 Brass		130-CT-PLUS._._	45-55	✓	✓	✓			✓				✓	✓	✓
		130-CT-PLUS-1._._	56-65	✓	✓	✓			✓				✓	✓	✓
		130-CT-PLUS-2._._	70-80	✓	✓	✓			✓				✓	✓	✓
		130-CT-PLUS-3._._	81-90	✓	✓	✓			✓				✓	✓	✓

120-CT

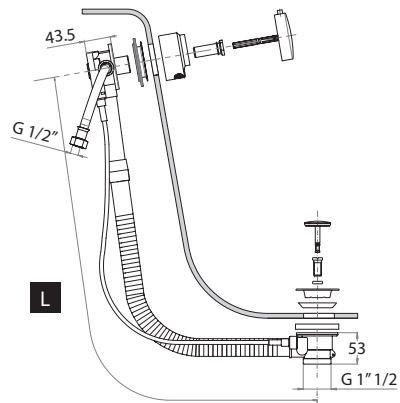

Colonna di scarico per vasca in ottone/rame
 • Trasmissione con movimento a cremagliera
 Bath pop-up waste & overflow in brass/copper
 • Rack and pinion drive system

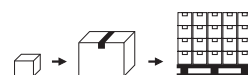

Imballo - Pack QxC QxB
 Cod 1 10 260

		Cod	L cm				
 6 Grooves ø 42 Brass	120-CT.01	45-55	✓	✓	✓	✓	
	120-CT-1.01	56-65	✓	✓	✓	✓	
	120-CT-2.01	70-80	✓	✓	✓	✓	
	120-CT-3.01	81-90	✓	✓	✓	✓	
 6 Grooves ø 72 ABS	120-CT-A.01	45-55	✓	✓	✓	✓	
	120-CT-A-1.01	56-65	✓	✓	✓	✓	
	120-CT-A-2.01	70-80	✓	✓	✓	✓	
	120-CT-A-3.01	81-90	✓	✓	✓	✓	
 6 Grooves ø 72 Brass	120-CT-L.01	45-55	✓	✓	✓	✓	
	120-CT-L-1.01	56-65	✓	✓	✓	✓	
	120-CT-L-2.01	70-80	✓	✓	✓	✓	
	120-CT-L-3.01	81-90	✓	✓	✓	✓	
 Minimal ø 42 Brass	120-CT-M.01	45-55	✓	✓	✓	✓	
	120-CT-M-1.01	56-65	✓	✓	✓	✓	
	120-CT-M-2.01	70-80	✓	✓	✓	✓	
	120-CT-M-3.01	81-90	✓	✓	✓	✓	
 Minimal ø 72 ABS	120-CT-MA.01	45-55	✓	✓	✓	✓	
	120-CT-MA-1.01	56-65	✓	✓	✓	✓	
	120-CT-MA-2.01	70-80	✓	✓	✓	✓	
	120-CT-MA-3.01	81-90	✓	✓	✓	✓	
 Minimal ø 72 Brass	120-CT-PLUS.01	45-55	✓	✓	✓	✓	
	120-CT-PLUS-1.01	56-65	✓	✓	✓	✓	
	120-CT-PLUS-2.01	70-80	✓	✓	✓	✓	
	120-CT-PLUS-3.01	81-90	✓	✓	✓	✓	

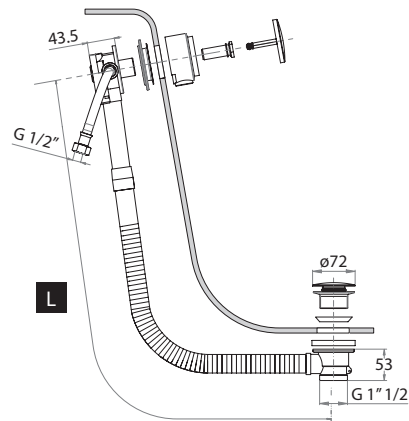

Differenti lunghezze fino a 125 cm
 Lengths available up to 125 cm

SK130

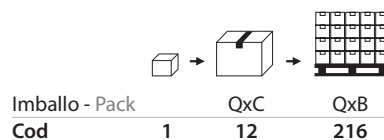

- Colonna di scarico per vasca in ottone/rame
- Sistema di comando "Skip-up" con "QuikFix"
- Bath "Skip-up" waste & overflow in brass/copper
- "Skip-up" plug system with "QuikFix"



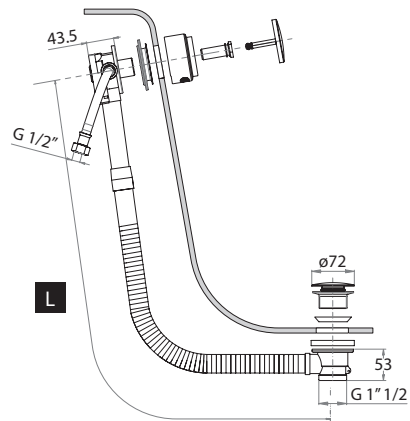

	Cod	L cm	○.01	○.16	○.33	○.35	○.43	○.25	○.26	○.38	○.40	○.12	PVD Lucido Glossy	PVD Spazzolato Brushed
 ø 72 Brass	SK130._._	45-55	✓	✓	✓			✓				✓	✓	✓
	SK130-1._._	56-65	✓	✓	✓			✓				✓	✓	✓
	SK130-2._._	70-80	✓	✓	✓			✓				✓	✓	✓
	SK130-3._._	81-90	✓	✓	✓			✓				✓	✓	✓
 ø 72 ABS	SK130-A._._	45-55	✓		✓			✓				✓		
	SK130-A-1._._	56-65	✓		✓			✓				✓		
	SK130-A-2._._	70-80	✓		✓			✓				✓		
	SK130-A-3._._	81-90	✓		✓			✓				✓		

SK120

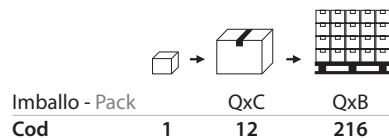

Colonna di scarico per vasca in ottone/rame
 • Sistema di comando "Skip-up" con "QuikFix"
 Bath "Skip-up" waste & overflow in brass/
 copper
 • "Skip-up" plug system with "QuikFix"



	Cod	L cm	.01	.33 .35 .43	.25 .26 .38 .40	.12
 ø 72 Brass	SK120._ _	45-55	✓	✓	✓	✓
	SK120-1._ _	56-65	✓	✓	✓	✓
	SK120-2._ _	70-80	✓	✓	✓	✓
	SK120-3._ _	81-90	✓	✓	✓	✓
 ø 72 ABS	SK120-A._ _	45-55	✓	✓	✓	✓
	SK120-A-1._ _	56-65	✓	✓	✓	✓
	SK120-A-2._ _	70-80	✓	✓	✓	✓
	SK120-A-3._ _	81-90	✓	✓	✓	✓

TK156

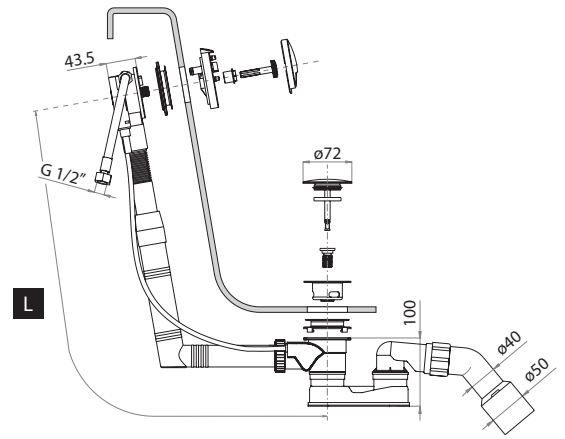

Colonna di scarico per vasca in polipropilene con bocca di erogazione al troppo pieno "Minimal Flat" completa di sifone ribassato preassemblato

- Tubo di troppo pieno "Flex-top"
- Tappo ø 72 mm in ABS con sistema basculante e filtro ispezionabile
- Predisposizione per intercambiabilità con sistema di comando a pressione "Skip-up"
- Disponibile per vasche standard e a sedile

Bath pop-up waste & overflow in polypropylene with "Minimal Flat" water outlet spout complete with pre-assembled low siphon

- "Flex-top" overflow pipe
- ø 72 mm ABS plug with overhead system and removable filter
- Plug is interchangeable with "Skip-up" style plug
- Available for standard and chair bathtubs

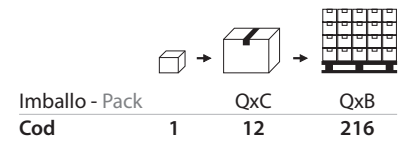

Cod	cm	L									
		.01	.33	.35	.43	.25	.26	.38	.40	.12	
TK156._ _	45-55	✓		✓			✓			✓	
TK156-1._ _	56-65	✓		✓			✓			✓	

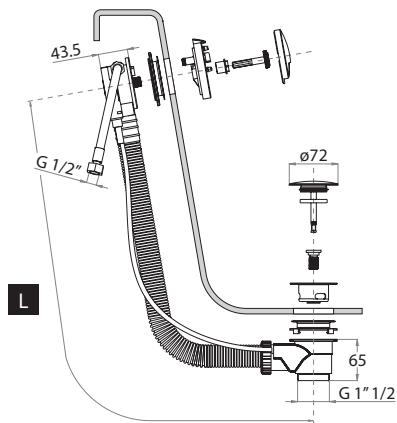

Colonna di scarico per vasca in polipropilene con bocca di erogazione al troppo pieno "Minimal Flat"

- Tubo di troppo pieno flessibile
 - Tappo ø 72 mm in ABS con sistema basculante e filtro ispezionabile
 - Predisposizione per intercambiabilità con sistema di comando a pressione "Skip-up"
 - Disponibile per vasche standard e a sedile
- Bath pop-up waste & overflow in polypropylene with "Minimal Flat" water outlet spout
- Flexible overflow pipe
 - ø 72 mm ABS plug with overhead system and removable filter
 - Plug is interchangeable with "Skip-up" style plug
 - Available for standard and chair bathtubs

Erogazione Bathfiller

Option

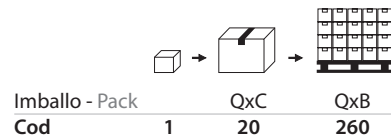

Cod	L cm	Color Options				Color Options				Color Option
		.01	.33	.35	.43	.25	.26	.38	.40	
157._.	45-55	✓				✓				✓
157-1._.	56-65	✓				✓				✓
157-2._.	70-80	✓				✓				✓
157-3._.	81-90	✓				✓				✓

122

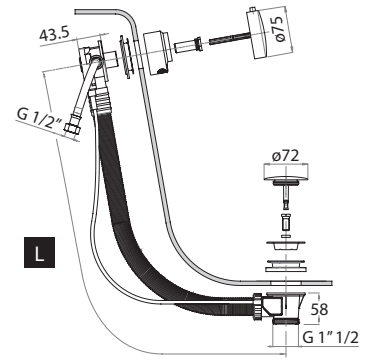

Colonna di scarico per vasca con bocca di erogazione "Clean" in ABS
 • Trasmissione con movimento a cremagliera
 Bath pop-up waste & overflow with water "Clean" water outlet spout in ABS
 • Rack and pinion drive system

Option

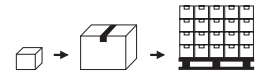

Imballo - Pack	1	20	260
Cod			

		Cod	L	cm	.01	.33	.35	.43	.25	.26	.38	.40	.12
 6 Grooves ø 42 Brass	122.01	45-55	✓										✓
	122-1.01	56-65	✓										✓
	122-2.01	70-80	✓										✓
	122-3.01	81-90	✓										✓
 6 Grooves ø 72 ABS	122-A.01	45-55	✓										✓
	122-A-1.01	56-65	✓										✓
	122-A-2.01	70-80	✓										✓
	122-A-3.01	81-90	✓										✓
 6 Grooves ø 72 Brass	122-L.01	45-55	✓										✓
	122-L-1.01	56-65	✓										✓
	122-L-2.01	70-80	✓										✓
	122-L-3.01	81-90	✓										✓
 Minimal ø 42 Brass	122-M.01	45-55	✓										✓
	122-M-1.01	56-65	✓										✓
	122-M-2.01	70-80	✓										✓
	122-M-3.01	81-90	✓										✓
 Minimal ø 72 ABS	122-MA.01	45-55	✓										✓
	122-MA-1.01	56-65	✓										✓
	122-MA-2.01	70-80	✓										✓
	122-MA-3.01	81-90	✓										✓
 Minimal ø 72 Brass	122-PLUS.01	45-55	✓										✓
	122-PLUS-1.01	56-65	✓										✓
	122-PLUS-2.01	70-80	✓										✓
	122-PLUS-3.01	81-90	✓										✓

132

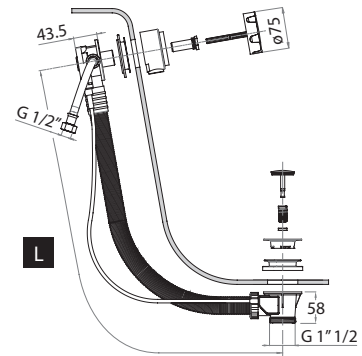

Colonna di scarico per vasca con bocca di erogazione in ottone con aeratore

- Trasmissione con movimento a cremagliera
- Bath pop-up waste & overflow with water outlet spout in brass with aerator
- Rack and pinion drive system

Option

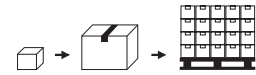

Imballo - Pack QxC QxB
 Cod 1 10 260

		Cod	L cm	.01	.16	.33 .35 .43	.25 .26 .38 .40	.12	PVD Lucido Glossy	PVD Spazzolato Brushed
 6 Grooves ø 42 Brass	132-__	45-55	✓	✓	✓	✓	✓	✓	✓	✓
	132-1-__	56-65	✓	✓	✓	✓	✓	✓	✓	✓
	132-2-__	70-80	✓	✓	✓	✓	✓	✓	✓	✓
	132-3-__	81-90	✓	✓	✓	✓	✓	✓	✓	✓
 6 Grooves ø 72 ABS	132-A-__	45-55	✓		✓	✓	✓	✓		
	132-A-1-__	56-65	✓		✓	✓	✓	✓		
	132-A-2-__	70-80	✓		✓	✓	✓	✓		
	132-A-3-__	81-90	✓		✓	✓	✓	✓		
 6 Grooves ø 72 Brass	132-L-__	45-55	✓	✓	✓	✓	✓	✓	✓	✓
	132-L-1-__	56-65	✓	✓	✓	✓	✓	✓	✓	✓
	132-L-2-__	70-80	✓	✓	✓	✓	✓	✓	✓	✓
	132-L-3-__	81-90	✓	✓	✓	✓	✓	✓	✓	✓
 Minimal ø 42 Brass	132-M-__	45-55	✓	✓	✓	✓	✓	✓	✓	✓
	132-M-1-__	56-65	✓	✓	✓	✓	✓	✓	✓	✓
	132-M-2-__	70-80	✓	✓	✓	✓	✓	✓	✓	✓
	132-M-3-__	81-90	✓	✓	✓	✓	✓	✓	✓	✓
 Minimal ø 72 ABS	132-MA-__	45-55	✓		✓	✓	✓	✓		
	132-MA-1-__	56-65	✓		✓	✓	✓	✓		
	132-MA-2-__	70-80	✓		✓	✓	✓	✓		
	132-MA-3-__	81-90	✓		✓	✓	✓	✓		
 Minimal ø 72 Brass	132-PLUS-__	45-55	✓	✓	✓	✓	✓	✓	✓	✓
	132-PLUS-1-__	56-65	✓	✓	✓	✓	✓	✓	✓	✓
	132-PLUS-2-__	70-80	✓	✓	✓	✓	✓	✓	✓	✓
	132-PLUS-3-__	81-90	✓	✓	✓	✓	✓	✓	✓	✓

Per opzioni vedere risvolto di copertina
 For options check the cover flap

Erogazione Bath filler

Differenti lunghezze fino a 125 cm
 Lengths available up to 125 cm

SK157 WRAS APPROVED PRODUCT

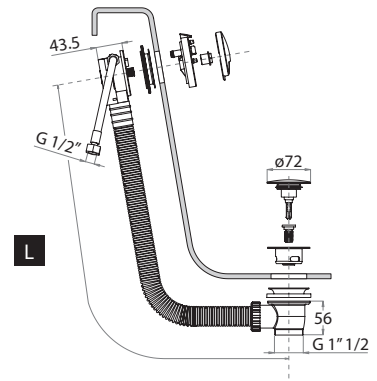

Colonna di scarico per vasca in polipropilene con bocca di erogazione al troppo pieno

- Sistema di comando "Skip-up" con "QuikFix"
- Tubo di troppo pieno flessibile



Bath "Skip-up" waste & overflow in polypropylene with water outlet spout

- "Skip-up" plug with "QuikFix" system
- Flexible overflow pipe

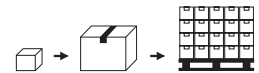
Option



Imballo - Pack	1	QxC	QxB
Cod	1	20	260

	Cod	L cm	.01	.33 .35 .43	.25 .26 .38 .40	.12
 ø 72 Brass	SK157._._	45-80	✓	✓	✓	✓
	SK157-1._._	81-125	✓	✓	✓	✓
 ø 72 ABS	SK157-A._._	45-80	✓	✓	✓	✓
	SK157-A-1._._	81-125	✓	✓	✓	✓

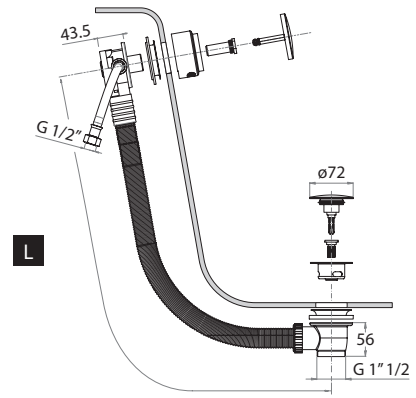



Colonna di scarico per vasca con bocca di erogazione al troppo pieno, tubo corrugato e scarico in polipropilene

- Sistema di comando "Skip-up" con "QuikFix"
 - Bocca di erogazione in ABS
- Polypropylene bath "Skip-up" waste & overflow with water outlet spout
- "Skip-up" plug with "QuikFix" system
 - "Clean" water outlet spout in ABS

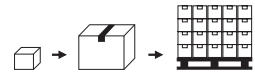
Option



Imballo - Pack	1	QxC	20	QxB	260
Cod					

	Cod	L cm				
 ø 72 Brass	SK122._._	45-80	✓	✓	✓	✓
	SK122-1._._	81-125	✓	✓	✓	✓
 ø 72 ABS	SK122-A._._	45-80	✓	✓	✓	✓
	SK122-A-1._._	81-125	✓	✓	✓	✓

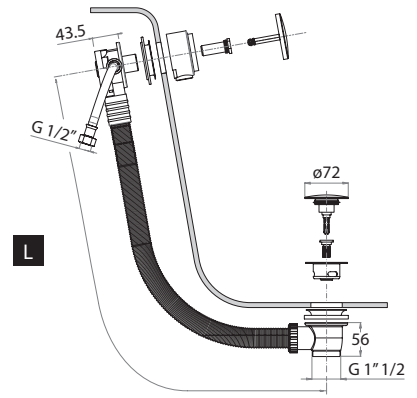

Colonna di scarico per vasca con bocca di erogazione al troppo pieno, tubo corrugato e scarico in polipropilene

- Sistema di comando "Skip-up" con "QuikFix"
- Bocca di erogazione in ottone



Polypropylene bath "Skip-up" waste & overflow with water outlet spout

- "Skip-up" plug with "QuikFix" system
- Brass water outlet spout

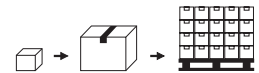
Option

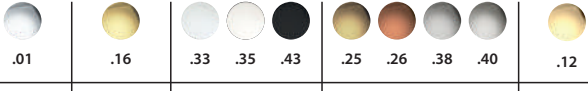

Imballo - Pack	1	QxC	QxB
Cod	1	20	260

	Cod	 cm		PVD Lucido Glossy	PVD Spazzolato Brushed				
	SK132._._	45-80	✓	✓	✓	✓	✓	✓	✓
	SK132-1._._	81-125	✓	✓	✓	✓	✓	✓	✓
	SK132-A._._	45-80	✓	✓	✓	✓	✓	✓	✓
	SK132-A-1._._	81-125	✓	✓	✓	✓	✓	✓	✓

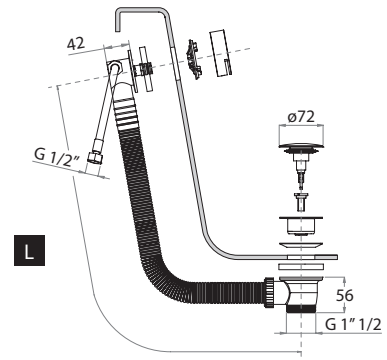



Colonna di scarico per vasca in polipropilene con bocca di erogazione "Fan" in ottone

- Sistema di comando "Skip-up" con "QuikFix"
 - Tubo di troppo pieno flessibile
- Bath "Skip-up" waste & overflow in polypropylene with "Fan" style water outlet
- "Skip-up" plug with "QuikFix" system
 - Flexible overflow pipe

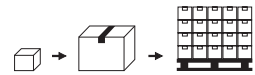
Option



Imballo - Pack	1	QxC	QxB
Cod	1	10	260

	Cod	L cm		PVD Lucido Glossy	PVD Spazzolato Brushed
 ø 72 Brass	SK134. __	45-80	✓	✓	✓
	SK134-1. __	81-125	✓	✓	✓
 ø 72 ABS	SK134-A. __	45-80	✓	✓	✓
	SK134-A-1. __	81-125	✓	✓	✓

SK134-INOX • TSK134-INOX



- Colonna di scarico per vasca in polipropilene
- Bocca di erogazione "Fan" e tappo ø 72 mm in acciaio inox AISI 316L
 - Sistema di comando "Skip-up" con "QuikFix"
 - Tubo di troppo pieno flessibile
- Bath "Skip-up" waste & overflow in polypropylene
- AISI 316L stainless steel "Fan" style water outlet spout and plug ø 72 mm
 - Skip-up" plug system with "QuikFix"
 - Flexible overflow pipe

Option

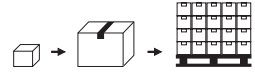

Imballo - Pack	1	QxC	12	QxB	216
Cod					



	Cod	L cm	
	SK134-INOX	45-125	✓
	TSK134-INOX	45-125	✓



10

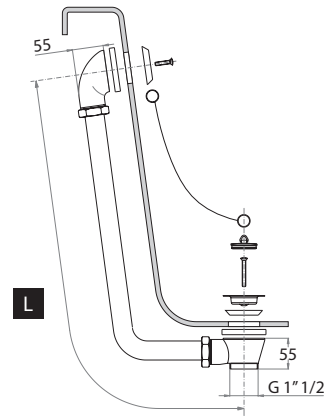

Colonna di scarico per vasca in ottone con tappo a catenella per vasche a vista
 Brass bath waste & overflow with plug and chain for exposed bathtubs



Imballo - Pack

Cod 1

Cod	L	cm	.01	.16	.33	.35	.43	.25	.26	.38	.40	.12
10_ _	L	45-65	✓	✓	✓			✓				✓

10+56-B

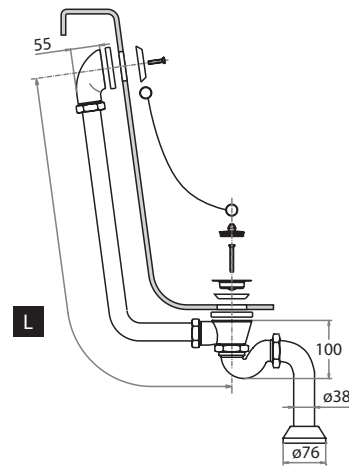

Colonna di scarico per vasca in ottone con tappo a catenella per vasche a vista
 Brass bath waste & overflow with plug and chain for exposed bathtubs



Imballo - Pack

Cod 1





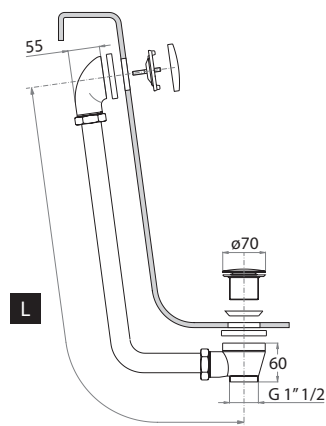



Cod	L	cm	.01	.16	.33	.35	.43	.25	.26	.38	.40	.12
10+56-B_ _	L	45-65	✓	✓	✓			✓				✓

SK10



Colonna di scarico per vasca in ottone con sistema di comando "Skip-up" per vasche a vista
Bath pop-up waste & overflow in brass with "Skip-up" plug system for exposed bathtubs

Imballo - Pack 
Cod 1





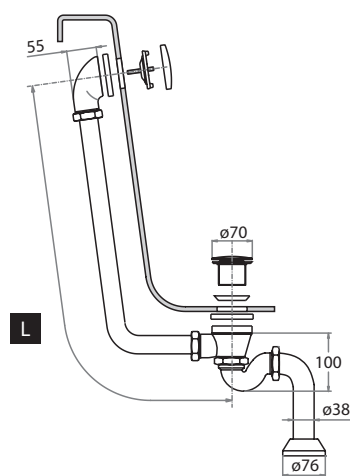





Cod	cm											
												
SK10._.	45-65	✓	✓	✓	✓	✓	✓	✓	✓	✓	✓	

SK10+56-B



Colonna di scarico per vasca in ottone con sistema di comando "Skip-up" per vasche a vista
Bath pop-up waste & overflow in brass with "Skip-up" plug system for exposed bathtubs

Imballo - Pack 
Cod 1

Cod	cm											
												
SK10+56-B._.	45-65	✓	✓	✓	✓	✓	✓	✓	✓	✓		

10A

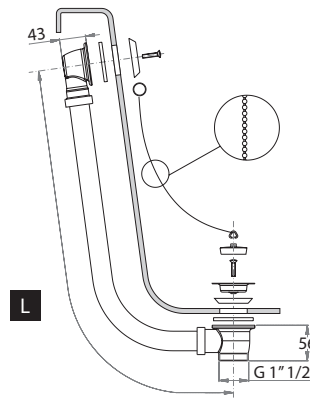

Colonna di scarico per vasca in ABS con tappo a catenella per vasche a vista
 ABS bath waste & overflow with plug and chain for exposed bathtubs



Imballo - Pack

Cod 1

Cod	L	cm	.01	.33	.35	.43	.25	.26	.38	.40	.12
10A._.	cm	45-65	✓	✓			✓				✓

10A+56-B

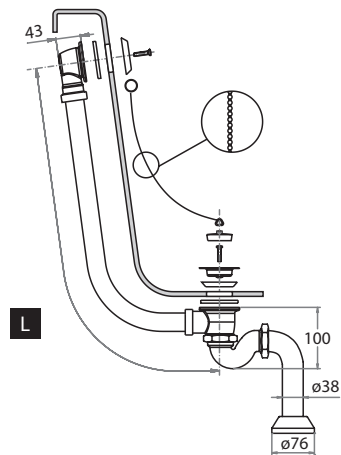

Colonna di scarico per vasca in ABS con tappo a catenella per vasche a vista
 ABS bath waste & overflow with plug and chain for exposed bathtubs



Imballo - Pack

Cod 1

Cod	L	cm	.01	.33	.35	.43	.25	.26	.38	.40	.12
10A._.+56-B	cm	45-65	✓	✓			✓				✓

SK10A

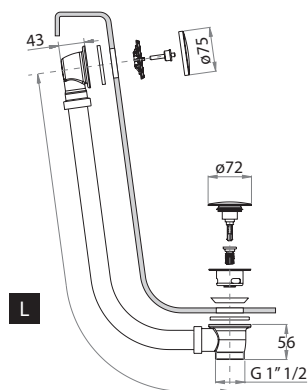

Colonna di scarico per vasca in ABS con sistema di comando "Skip-up" per vasche a vista
Bath pop-up waste & overflow in ABS with "Skip-up" plug system for exposed bathtubs



Imballo - Pack

Cod 1

Cod	L cm	Color				Color				Color
		.01	.33	.35	.43	.25	.26	.38	.40	
SK10A._.	45-65	✓		✓		✓				✓

SK10A+56-B

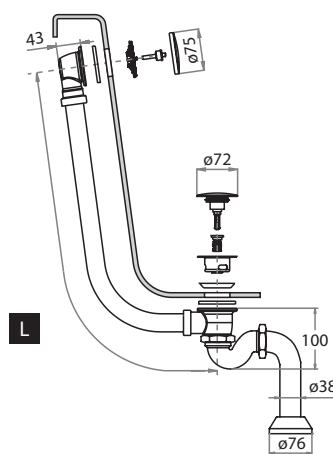

Colonna di scarico per vasca in ABS con sistema di comando "Skip-up" per vasche a vista
Bath pop-up waste & overflow in ABS with "Skip-up" plug system for exposed bathtubs



Imballo - Pack

Cod 1

Cod	L cm	Color				Color				Color
		.01	.33	.35	.43	.25	.26	.38	.40	
SK10A._.+56-B	45-65	✓		✓		✓				✓

11

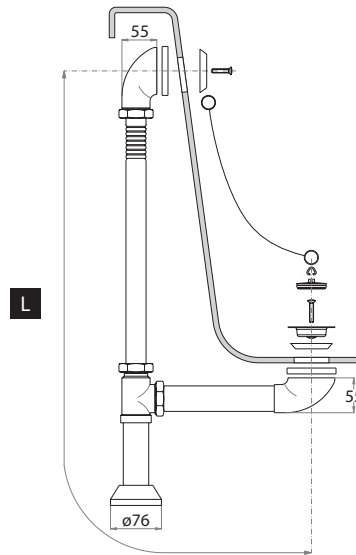









Colonna di scarico per vasca in ottone con tappo a catenella per vasche a vista, modello "America"
Brass bath waste & overflow with plug and chain for exposed bathtubs, "America" model



Imballo - Pack

Cod 1

Cod	cm										
		.01	.16	.33	.35	.43	.25	.26	.38	.40	.12
11. __	45-65	✓	✓	✓			✓				✓

SK11

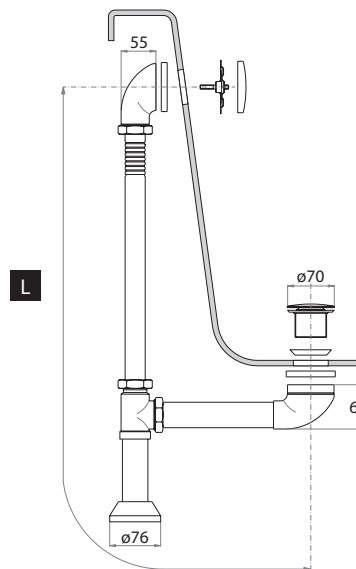











Colonna di scarico per vasca in ottone con sistema di comando "Skip-up" per vasche a vista, modello "America"
Bath pop-up waste & overflow in brass with "Skip-up" plug system for exposed bathtubs, "America" model



Imballo - Pack

Cod 1

Cod	cm										
		.01	.16	.33	.35	.43	.25	.26	.38	.40	.12
SK11. __	45-65	✓	✓	✓			✓				✓

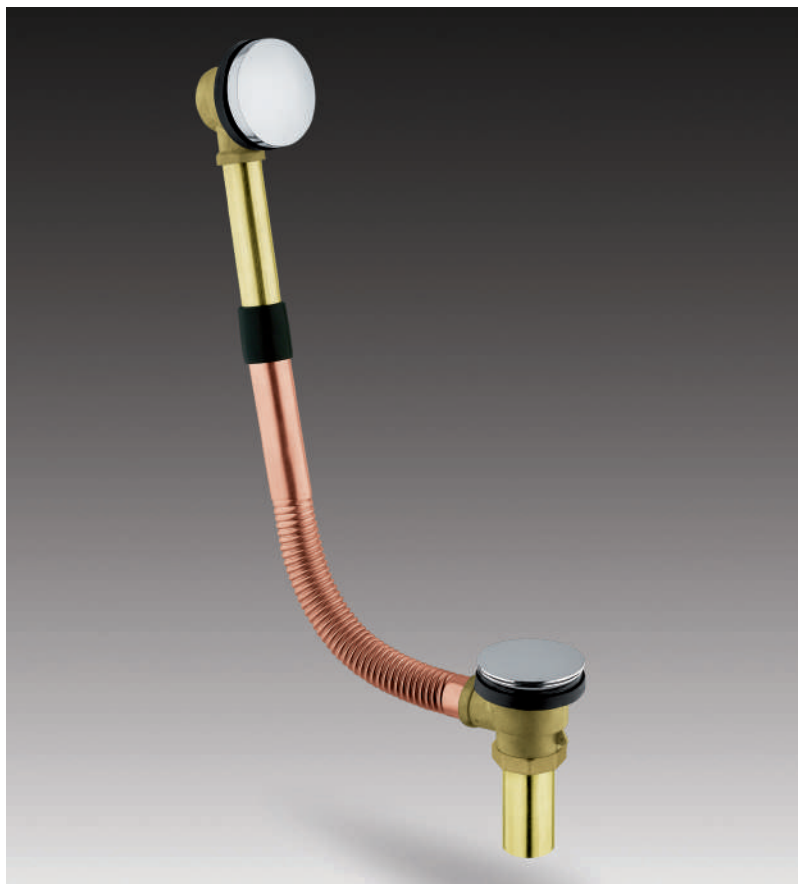

ST5990N

Sifone per piatto doccia foro \varnothing 90 mm

- Scarico verticale 2" DWV
 - Tappo di copertura liscio \varnothing 110 mm in ABS
 - Portata > 60 l/min
- \varnothing 90 mm vertical shower tray drain
- \varnothing 110 mm smooth ABS cover
 - 2" DWV vertical outlet
 - Flow rate > 60 l/min

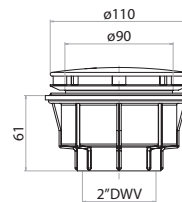

Cod		
ST5990._.N	✓ ✓	✓ ✓

Imballo - Pack	QxC	QxB
Cod	1	30
		720

ST5990

Sifone per piatto doccia foro \varnothing 90 mm

- Scarico verticale 2" DWV
 - Tappo di copertura con linea in rilievo \varnothing 120 mm in ABS
 - Portata > 60 l/min
- \varnothing 90 mm vertical shower tray drain
- \varnothing 120 mm ABS cover with boss linea design
 - 2" DWV vertical outlet
 - Flow rate > 60 l/min

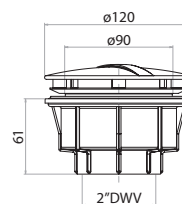

Cod		
ST5990._.	✓	✓ ✓



Imballo - Pack	QxC	QxB
Cod	1	30
		720

ST9390N

Sifone per piatto doccia foro \varnothing 90 mm

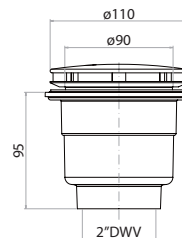
- Scarico verticale 2" DWV
 - Tappo di copertura liscio \varnothing 110 mm in ABS
 - Portata > 60 l/min
- \varnothing 90 mm vertical shower tray drain
- \varnothing 110 mm smooth ABS cover
 - 2" DWV vertical outlet
 - Flow rate > 60 l/min



Cod		
ST9390._.N	✓ ✓	✓ ✓

Imballo - Pack	QxC	QxB
Cod	1	30
		600

ST9390

Sifone per piatto doccia foro \varnothing 90 mm

- Scarico verticale 2" DWV
 - Tappo di copertura con linea in rilievo \varnothing 120 mm in ABS
 - Portata > 60 l/min
- \varnothing 90 mm vertical shower tray drain
- \varnothing 120 mm ABS cover with boss linea design
 - 2" DWV vertical outlet
 - Flow rate > 60 l/min

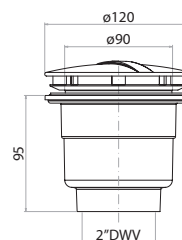

Cod		
ST9390._.	✓ ✓	✓ ✓



Imballo - Pack	QxC	QxB
Cod	1	30
		600

SKN330C

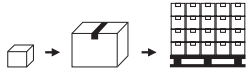
Scarico 1" 1/4 in ottone per lavabo, modello "Universale"
Brass waste 1" 1/4 for washbasin, "Universal" model

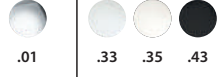

Imballo - Pack QxC QxB
Cod 1 20 560

	Cod	 mm	
 Skip-up 2.0	SKN330.___C	0-70	✓
 Free-flow	SKN330.___CSA	0-70	✓

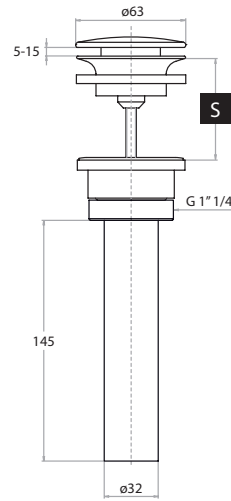

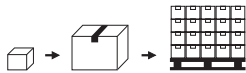

SKN340C

Scarico 1" 1/4 in ottone per lavabo, modello "Universale"
• Tappo in ceramica
Brass waste 1" 1/4 for washbasin, "Universal" model
• **Ceramic plug**



Imballo - Pack QxC QxB
Cod 1 20 560

	Cod	 mm	
 Skip-up 2.0	SKN340.01C	0-70	✓
 Free-flow	SKN340.01CSA	0-70	✓

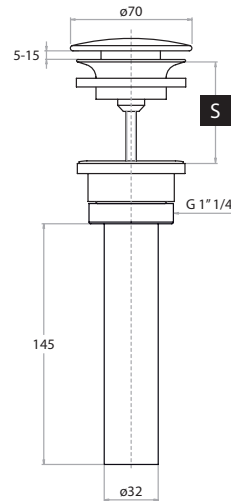



NEW

SKN330-INOXC

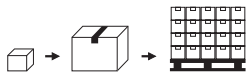
Scarico 1" 1/4 in acciaio INOX per lavabo, modello "Universale"
Stainless steel waste 1" 1/4 for washbasin, "Universal" model



Imballo - Pack QxC QxB
Cod 1 20 560

	Cod	 mm	
 Skip-up 2.0	SKN330-INOXC	0-70	✓
 Free-flow	SKN330-INOXCSEA	0-70	✓

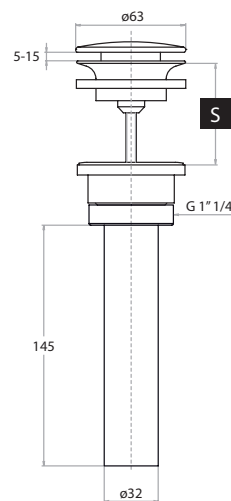



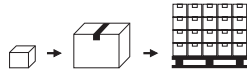

NEW

SKN230C

Scarico 1" 1/4 in ottone per lavabo, modello "Universale"
 Brass waste 1" 1/4 for washbasin, "Universal" model



Imballo - Pack	1	20	560
Cod			

	Cod	 mm	
 Skip-up 2.0	SKN230._.C	5-70	✓
 Free-flow	SKN230._.CSA	5-70	✓

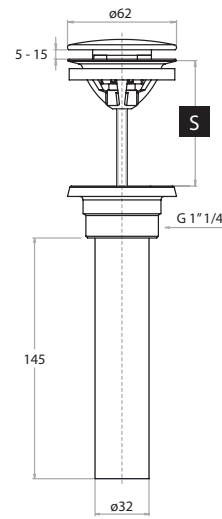

NEW



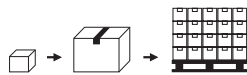

SKN250C

Scarico 1" 1/4 in ottone per lavabo, modello "Universale"
 • Tappo in Corian®
 Brass waste 1" 1/4 for washbasin, "Universal" model
 • Corian® plug



Imballo - Pack	1	20	560
Cod			

	Cod	 mm	
 Skip-up 2.0	SKN250.01C	5-70	✓
 Free-flow	SKN250.01CSA	5-70	✓

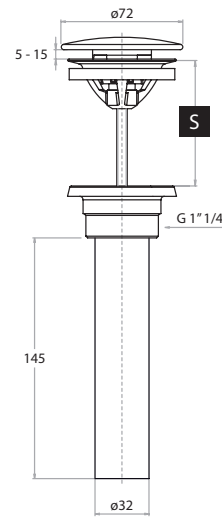

NEW







SKN300C

Scarico 1" 1/4 in ottone per lavabo

• **Con troppo pieno**

Brass waste 1" 1/4 for washbasin

• **With overflow**

	Cod	 mm	
 Skip-up 2.0	SKN300.___C	35-40	✓ ✓ ✓ ✓ ✓
	SKN300-1.___C	40-60	✓ ✓ ✓ ✓ ✓
	SKN300-2.___C	70-85	✓ ✓
 Free-flow	SKN300.___CSA	35-40	✓ ✓
	SKN300-1.___CSA	40-60	✓ ✓
	SKN300-2.___CSA	70-85	✓ ✓ ✓ ✓ ✓

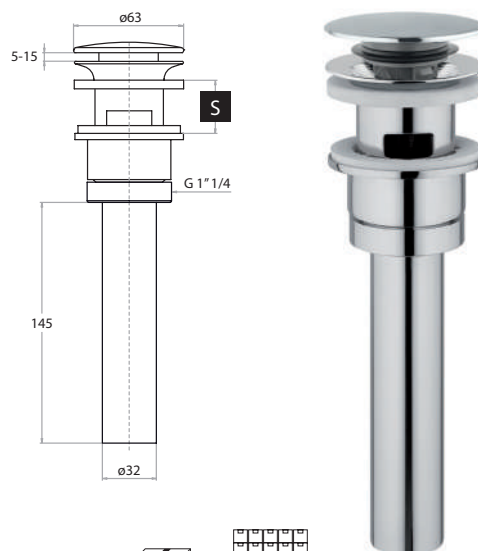

Imballo - Pack	1	20	560
Cod		QxC	QxB



SKN301C

Scarico 1" 1/4 in ottone per lavabo

• **Senza troppo pieno**

Brass waste 1" 1/4 for washbasin

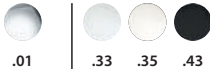
• **Without overflow**

	Cod	 mm	
 Skip-up 2.0	SKN301.___C	35-40	✓ ✓ ✓ ✓ ✓
	SKN301-1.___C	40-60	✓ ✓ ✓ ✓ ✓
	SKN301-2.___C	70-85	✓ ✓
 Free-flow	SKN301.___CSA	35-40	✓ ✓ ✓ ✓ ✓
	SKN301-1.___CSA	40-60	✓ ✓
	SKN301-2.___CSA	70-85	✓ ✓

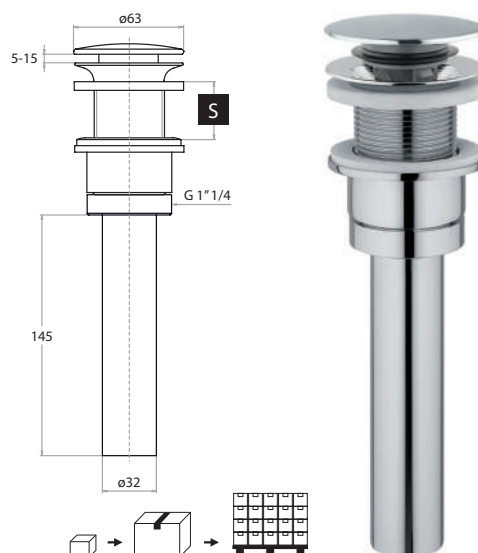

Imballo - Pack	1	20	560
Cod		QxC	QxB

SKN300COC

Scarico 1" 1/4 in ottone per lavabo







- **Con troppo pieno**
- Controdado ottone

Brass waste 1" 1/4 for washbasin

- **With overflow**
- Brass lock nut

Option

CP

		S				
	Cod	mm	.01	.33	.35	.43
 Skip-up 2.0	SKN300-1CO._C	30-50	✓	✓	✓	✓
	SKN300-2CO._C	35-70	✓	✓	✓	✓
 Free-flow	SKN300-1CO._CSA	30-50	✓	✓	✓	✓
	SKN300-2CO._CSA	35-70	✓		✓	

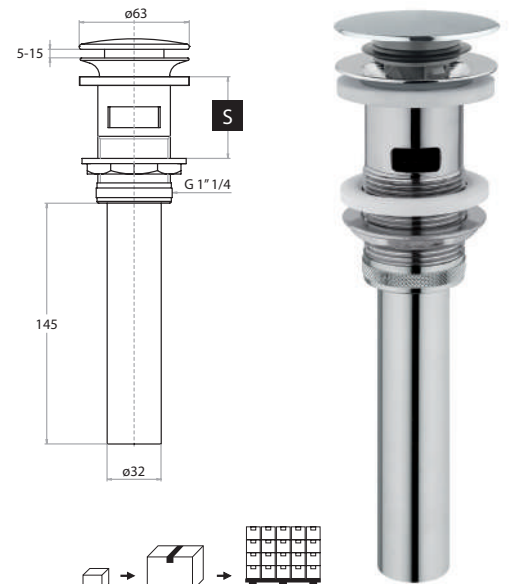

Imballo - Pack	1	QxC	20	QxB	560
Cod					

SKN301COC

Scarico 1" 1/4 in ottone per lavabo







- **Senza troppo pieno**
- Controdado ottone

Brass waste 1" 1/4 for washbasin

- **Without overflow**
- Brass lock nut

Option

CP

		S				
	Cod	mm	.01	.33	.35	.43
 Skip-up 2.0	SKN301CO._C	35-40	✓		✓	
	SKN301-1CO._C	40-60	✓		✓	
	SKN301-2CO._C	70-85	✓		✓	
 Free-flow	SKN301CO._CSA	35-40	✓	✓	✓	✓
	SKN301-1CO._CSA	40-60	✓	✓	✓	✓
	SKN301-2CO._CSA	70-85	✓	✓	✓	✓

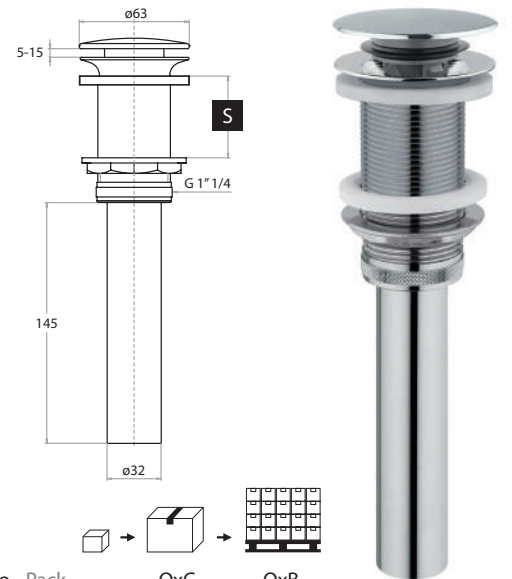

Imballo - Pack	1	QxC	20	QxB	560
Cod					

5200C



Scarico 1" 1/4 sabbia per lavabo

- Tappo ottone ali plastica
- Calotta ottone, asta acciaio

1" 1/4 brass sandblasted pop-up waste for washbasin

- Brass plug with plastic stem
- Brass coupling, stainless steel shaft

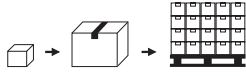

Imballo - Pack	1	QxC	20	QxB	560
Cod	1	20	560		

Cod	mm	S			
		.01	.33	.35	.43
5200._C	30-45	✓			✓
5202._C	46-60	✓			✓
5026._C	61-75	✓			✓

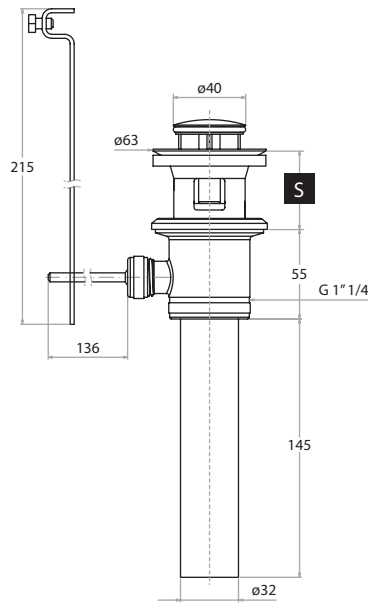

AL200C



Sifone ottone in tubo 1" 1/4

- Per lavabo

1" 1/4 brass washbasin p-trap

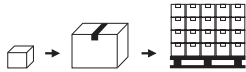

Imballo - Pack	1	QxC	10	QxB	180
Cod	1	10	180		

Cod	
AL200.01C	✓

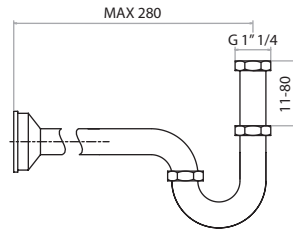

SKN20C

Scarico per vasca con troppo pieno integrato



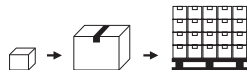

- Tappo ottone ø 72 mm con meccanismo a pressione "Skip-up 2.0", sistema "QuikFix"

Bath waste & overflow with integrated overflow

- "QuikFix" system ø 72 mm "Skip-up 2.0" brass plug



Imballo - Pack	1	30	600
Cod			

Cod	S				
	mm	.01	.33	.35	.43
SKN20._.C	0-70	✓		✓	

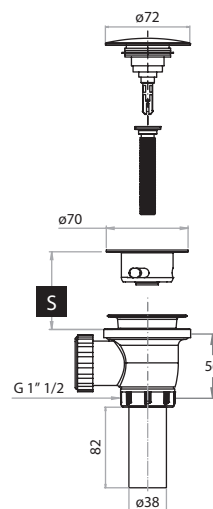

NEW

SKN20-INOXC

Scarico per vasca con troppo pieno integrato

- Tappo acciaio INOX ø 72 mm con meccanismo a pressione "Skip-up 2.0", sistema "QuikFix"

Bath waste & overflow with integrated overflow

- "QuikFix" system ø 72 mm "Skip-up 2.0" stainless steel plug



Imballo - Pack	1	30	600
Cod			

Cod	S	
	mm	
SKN20-INOXC	0-70	✓

INOX
AISI 316L

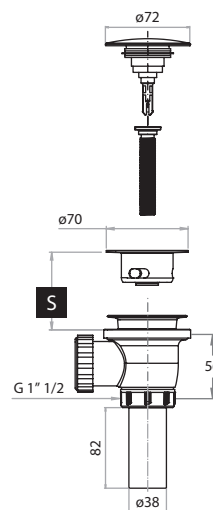

NEW

SKN22C

Scarico per vasca con troppo pieno integrato



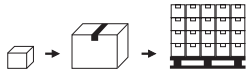

- Tappo ottone ø 72 mm con meccanismo a pressione "Skip-up 2.0", sistema "QuikFix"

Bath waste & overflow with integrated overflow

- "QuikFix" system ø 72 mm "Skip-up 2.0" brass plug



Imballo - Pack	1	QxC	30	QxB	600
Cod					

	S				
Cod	mm	.01	.33	.35	.43
SKN22._.C	15-85	✓		✓	

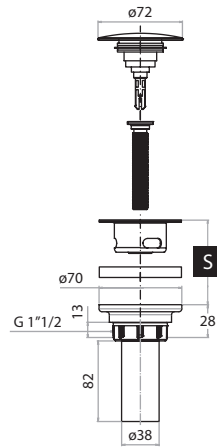

SKN22-INOXC

Scarico per vasca con troppo pieno integrato

- Tappo acciaio INOX ø 72 mm con meccanismo a pressione "Skip-up 2.0", sistema "QuikFix"

Bath waste & overflow with integrated overflow

- "QuikFix" system ø 72 mm "Skip-up 2.0" stainless steel plug

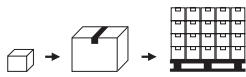

Imballo - Pack	1	QxC	30	QxB	600
Cod					

	S	
Cod	mm	
SKN22-INOXC	15-85	✓

INOX
AISI 316L

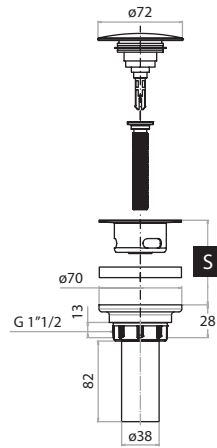

SKN23C

Scarico per vasca con troppo pieno integrato

- Tappo Corian® ø 72 mm con meccanismo a pressione "Skip-up 2.0", sistema "QuikFix"

Bath waste & overflow with integrated overflow

- "QuikFix" system ø 72 mm "Skip-up 2.0" Corian® plug

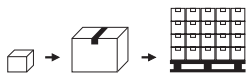

Imballo - Pack	1	QxC	30	QxB	600
Cod					

	S	
Cod	mm	
SKN23.01C	15-85	✓

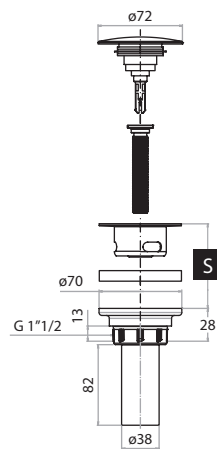

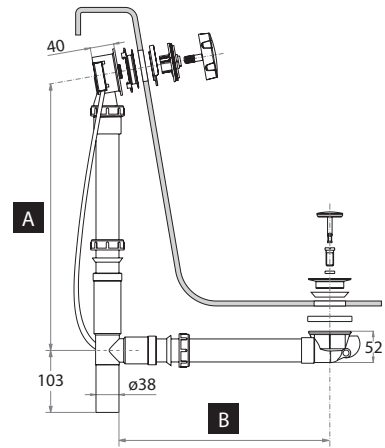



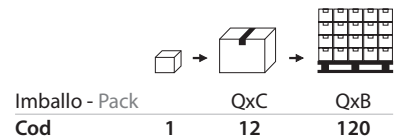

Colonna di scarico in ABS modello "America"

- Sistema di fissaggio a scatto
 - Raccordo a "T" di collegamento
- ABS "America" model bath pop-up waste and overflow
- With "snap-in" fixing system
 - Adjustable overflow
 - "T" standstill outlet connection

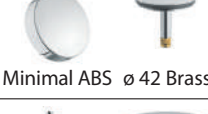
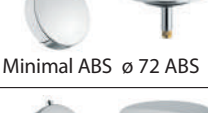



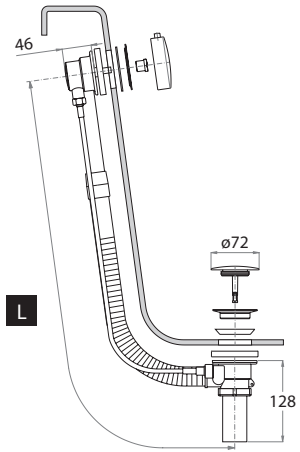
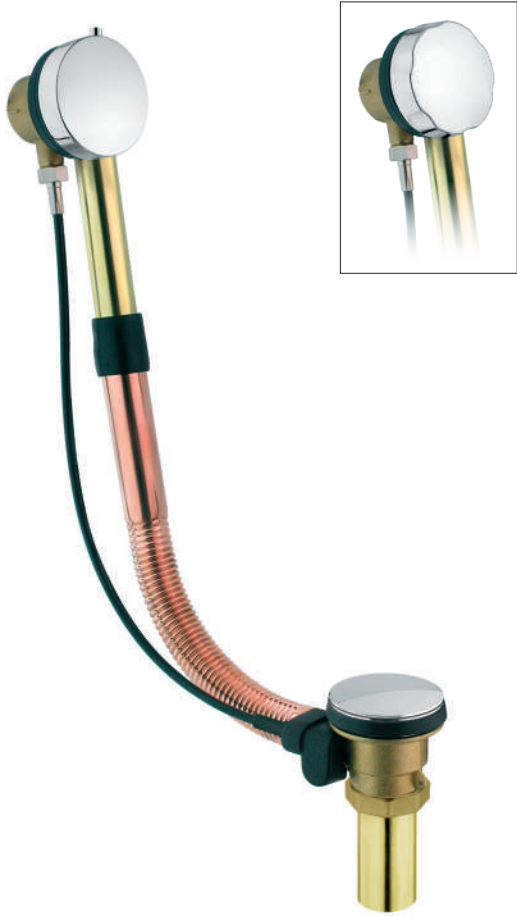



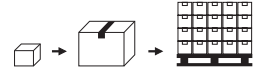









	Cod	A	B				
		cm	cm	.01	.33	.35	.43
 6 Grooves ABS ø 42 Brass	110-N-1._.	33-43	25-29	✓		✓	
	110-N-2._.	47-57	31-35	✓		✓	
	110-N-3._.	57-67	31-35	✓		✓	
 6 Grooves ABS ø 72 ABS	110-N-A-1._.	33-43	25-29	✓		✓	
	110-N-A-2._.	47-57	31-35	✓		✓	
	110-N-A-3._.	57-67	31-35	✓		✓	
 6 Grooves ABS ø 72 Brass	110-N-L-1._.	33-43	25-29	✓		✓	
	110-N-L-2._.	47-57	31-35	✓		✓	
	110-N-L-3._.	57-67	31-35	✓		✓	
 Minimal ABS ø 42 Brass	110-N-M-1._.	33-43	25-29	✓		✓	
	110-N-M-2._.	47-57	31-35	✓		✓	
	110-N-M-3._.	57-67	31-35	✓		✓	
 Minimal ABS ø 72 ABS	110-N-MA-1._.	33-43	25-29	✓		✓	
	110-N-MA-2._.	47-57	31-35	✓		✓	
	110-N-MA-3._.	57-67	31-35	✓		✓	
 Minimal ABS ø 72 Brass	110-N-PLUS-1._.	33-43	25-29	✓		✓	
	110-N-PLUS-2._.	47-57	31-35	✓		✓	
	110-N-PLUS-3._.	57-67	31-35	✓		✓	



Colonna di scarico in ottone/rame
 • Trasmissione con movimento "Eccentric"
 Brass/copper bath pop-up waste and overflow
 • All interior components are brass
 • "Eccentric" drive system



Imballo - Pack		QxC	QxB
Cod, Cod-1	1	20	260
Cod-2, Cod-3	1	12	120

		Cod	L cm				
				.01	.33	.35	.43
 6 Grooves  ø 42 Brass	48-__C	45-55	✓			✓	
	48-1-__C	56-65	✓			✓	
	48-2-__C	70-80	✓			✓	
	48-3-__C	81-90	✓			✓	
 6 Grooves  ø 72 ABS	48-A-__C	45-55	✓			✓	
	48-A-1-__C	56-65	✓			✓	
	48-A-2-__C	70-80	✓			✓	
	48-A-3-__C	81-90	✓			✓	
 6 Grooves  ø 72 Brass	48-L-__C	45-55	✓			✓	
	48-L-1-__C	56-65	✓			✓	
	48-L-2-__C	70-80	✓			✓	
	48-L-3-__C	81-90	✓			✓	
 Minimal  ø 42 Brass	48-M-__C	45-55	✓			✓	
	48-M-1-__C	56-65	✓			✓	
	48-M-2-__C	70-80	✓			✓	
	48-M-3-__C	81-90	✓			✓	
 Minimal  ø 72 ABS	48-MA-__C	45-55	✓			✓	
	48-MA-1-__C	56-65	✓			✓	
	48-MA-2-__C	70-80	✓			✓	
	48-MA-3-__C	81-90	✓			✓	
 Minimal  ø 72 Brass	48-PLUS-__C	45-55	✓			✓	
	48-PLUS-1-__C	56-65	✓			✓	
	48-PLUS-2-__C	70-80	✓			✓	
	48-PLUS-3-__C	81-90	✓			✓	

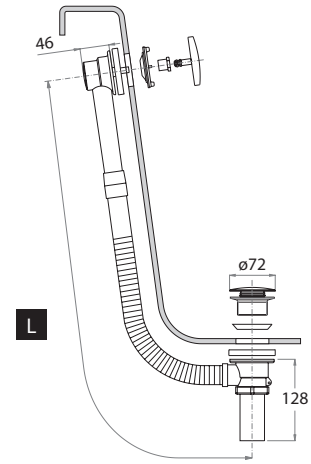



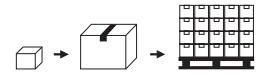

Colonna di scarico per vasca in ottone/rame

- Sistema di apertura/chiusura di scarico a pressione "Skip-up"

"Skip-up" brass/copper bath waste and overflow



Imballo - Pack	QxC	QxB
Cod, Cod-1	1	20
Cod-2, Cod-3	1	12
		260
		120

	Cod	 cm	
 ø 72 Brass	SK048._.C	45-55	✓
	SK048-1._.C	56-65	✓
	SK048-2._.C	70-80	✓
	SK048-3._.C	81-90	✓
 ø 72 ABS	SK048-A._.C	45-55	✓
	SK048-A-1._.C	56-65	✓
	SK048-A-2._.C	70-80	✓
	SK048-A-3._.C	81-90	✓

10+52BC 

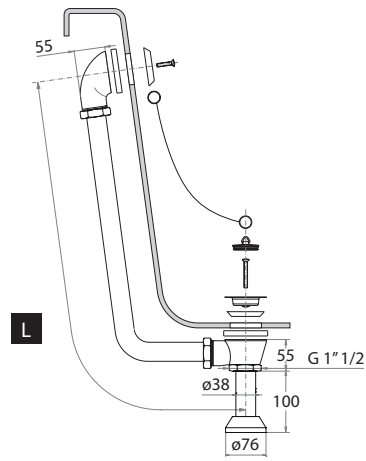

- Colonna di scarico per vasca in ottone
- Per vasche a vista
 - Con tappo a catenella
 - Completa di codolo diritto e rosone a pavimento
- Exposed brass bath waste and overflow
- Brass plug and chain
 - Complete with straight tail piece and drain outlet cover



Imballo - Pack _____
Cod 1

Cod	L cm	
10+52B._C	45-65	✓

SK10+52BC 

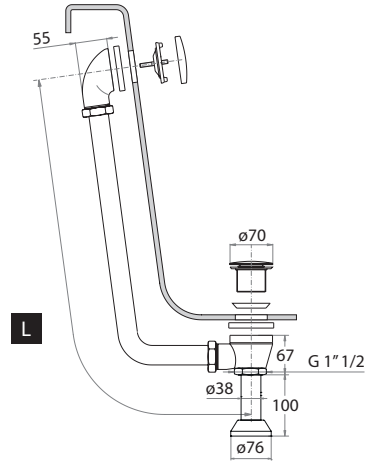

- Colonna di scarico per vasca in ABS
- Per vasche a vista
 - Sistema di apertura/chiusura di scarico a pressione "Skip-up"
 - Tappo ø 72 mm in ottone
 - Completa di codolo diritto e rosone a pavimento
- Exposed ABS bath "Skip-up" waste and overflow
- ø 72 mm brass plug
 - Complete with straight tail piece and drain outlet cover



Imballo - Pack _____
Cod 1

Cod	L cm	
SK10+52B._C	45-65	✓

CSA products

10A+52BC 

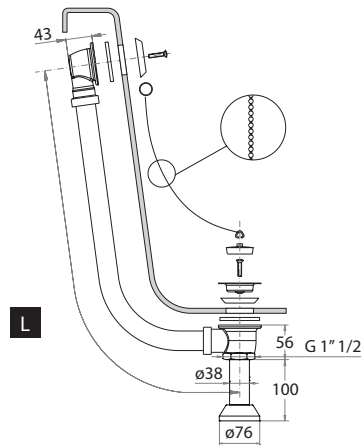

Colonna di scarico per vasca in ABS

- Per vasche a vista
- Con tappo a catenella
- Completa di codolo diritto e rosone a pavimento

Exposed ABS bath waste and overflow

- Plug and chain
- Complete with straight tail piece and drain outlet cover



Imballo - Pack

Cod 1

Cod	cm	L	Color			
			.01	.33	.35	.43
10A+52B._C	45-65	✓	✓			

SK10A+52BC 

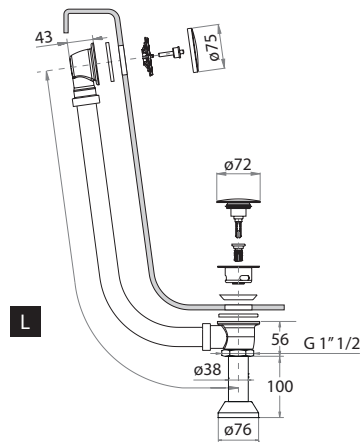

Colonna di scarico per vasca in ABS

- Per vasche a vista
- Sistema di apertura/chiusura di scarico a pressione "Skip-up"
- Tappo ø 72 mm in ottone
- Completa di codolo diritto e rosone a pavimento

Exposed ABS bath "Skip-up" waste and overflow

- ø 72 mm brass plug
- Complete with straight tail piece and drain outlet cover



Imballo - Pack

Cod 1

Cod	cm	L	Color			
			.01	.33	.35	.43
SK10A+52B._C	45-65	✓	✓			

11  C US

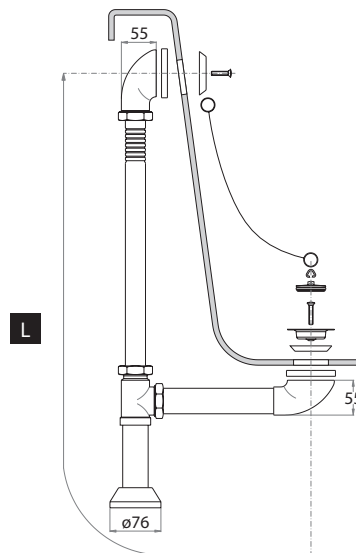

Colonna di scarico per vasca in ottone con tappo a catenella per vasche a vista, modello "America"
Brass bath waste & overflow with plug and chain for exposed bathtubs, "America" model



Imballo - Pack

Cod 1

L

Cod

cm

11.01

45-65

✓

SK11  C US

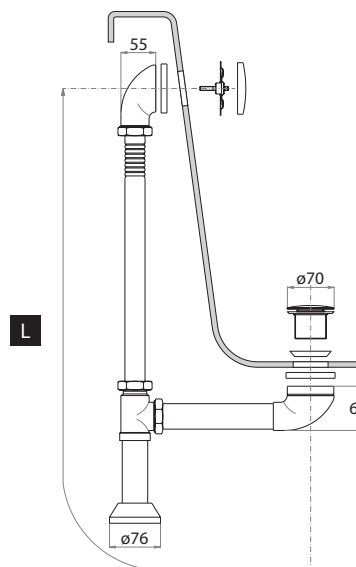

Colonna di scarico per vasca in ottone con sistema di comando "Skip-up" per vasche a vista, modello "America"
Bath pop-up waste & overflow in brass with "Skip-up" plug system for exposed bathtubs, "America" model



Imballo - Pack

Cod 1

L

Cod

cm

SK11.01

45-65

✓

CSA products



GLT10

Nuovo sistema antigocciolamento per doccette estraibili a bordo vasca
 New anti-drip system for removable bathtub shower heads and hand showers
 • Round pull-out shower head

Cod

GLT10.01	✓
----------	---

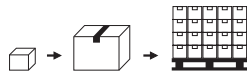

Imballo - Pack	1	QxC	20	QxB	260
Cod	1	20	260		

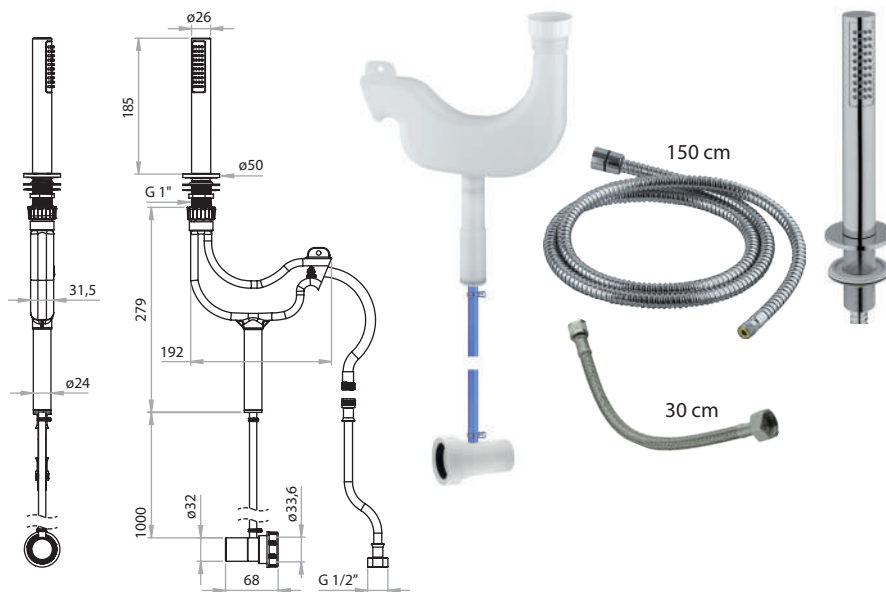

GLT10M

Kit composto da GLT10.01 + Molla di richiamo
 Kit: GLT10.01 + Return spring

Cod

GLT10M.01	✓
-----------	---

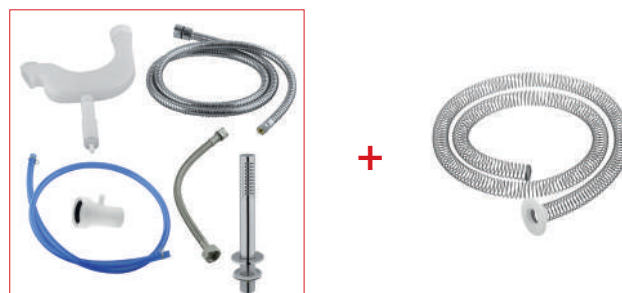

GLQ10

Nuovo sistema antigocciolamento per doccette estraibili a bordo vasca
 New anti-drip system for removable bathtub shower heads and hand showers
 • Square pull-out shower head

Cod

GLQ10.01	✓
----------	---

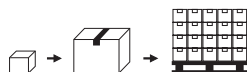

Imballo - Pack	1	QxC	20	QxB	260
Cod	1	20	260		

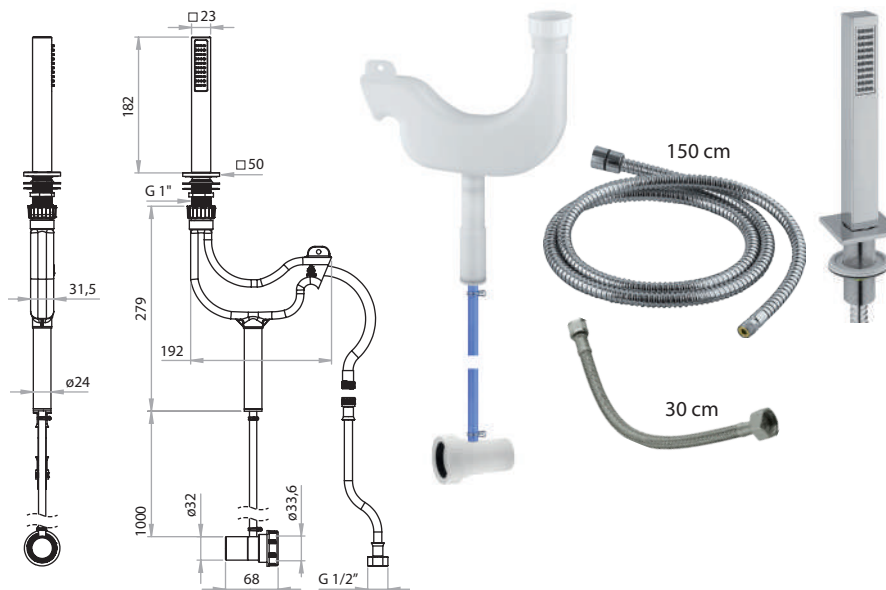

GLQ10M

Kit composto da GLT10.01 + Molla di richiamo
 Kit: GLT10.01 + Return spring

Cod

GLQ10M.01	✓
-----------	---

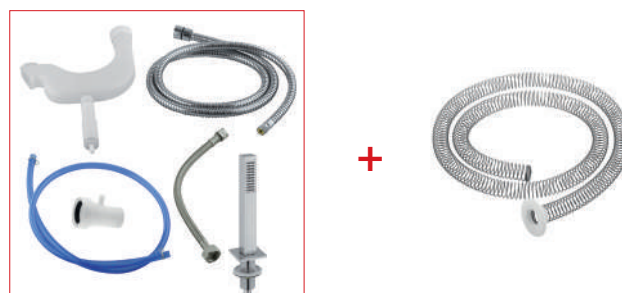

GL10

Nuovo sistema antigocciolamento per doccette estraibili a bordo vasca
New anti-drip system for removable bathtub shower heads and hand showers

Cod

GL10	✓
------	---

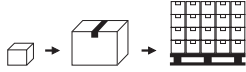

Imballo - Pack	1	QxC	20	QxB	260
Cod	1	20	260		

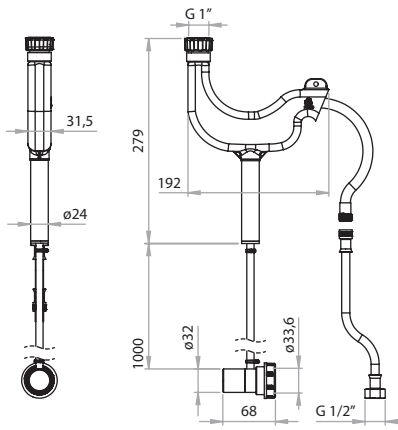

GL10M

Kit composto da GL10 + Molla di richiamo
Kit: GL10 + Return spring

Cod

GL10M	✓
-------	---

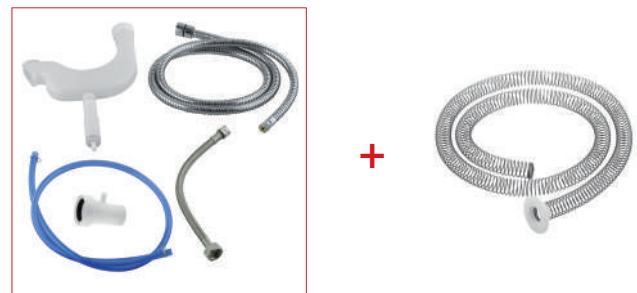

GL10SF

Nuovo sistema antigocciolamento per doccette estraibili a bordo vasca
New anti-drip system for removable bathtub shower heads and hand showers

Cod

GLT10SF	✓
---------	---

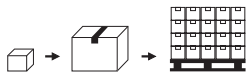

Imballo - Pack	1	QxC	20	QxB	260
Cod	1	20	260		

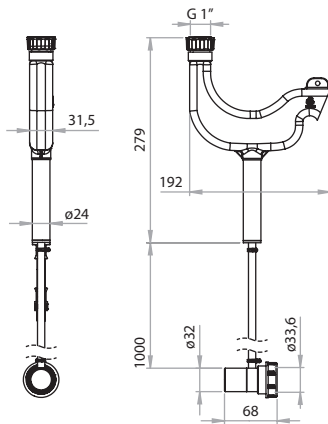

SKVC14

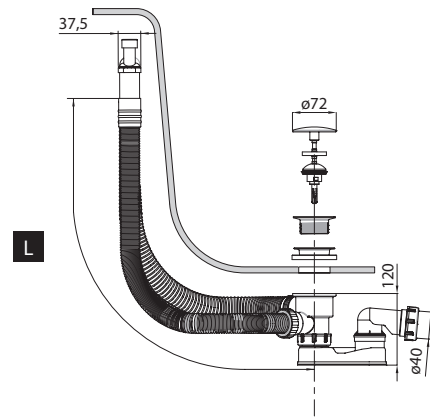

Colonna di scarico per vasca "Think Minimal"

- Troppo pieno occulto
- Tappo \varnothing 72 mm in ottone con filtro ispezionabile
- Apertura/chiusura con sistema a pressione "Skip-up"
- Tubi corrugati flessibili

"Think Minimal" bath waste & overflow

- Concealed overflow
- \varnothing 72 mm "Skip-up" brass plug with inspectable filter
- Flexible pipes



Imballo - Pack

Cod 1

Cod	L cm	
SKVC14.01C	80	✓
SKVC14-1.01C	120	✓

SK14-SCT

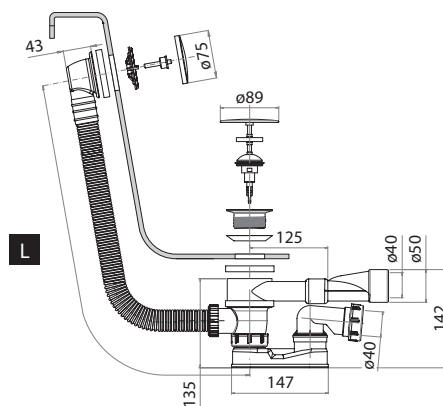

Colonna di scarico per vasca con aspirazione

- Tappo "Skip-up" \varnothing 89 mm in ottone
- Tubo corrugato flessibile
- Copertura troppo pieno in zama
- Sifone ribassato 64-B

Bath waste & overflow with suction

- \varnothing 89 mm "Skip-up" brass plug
- Flexible pipe
- Overflow cover in Zamak
- Low siphon 64-B

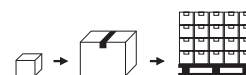

Imballo - Pack QxC QxB
Cod 1 12 216

L

Cod

cm

SK14-SCT.01	45-80	✓
SK14-SCT-1.01	81-125	✓

SK134-SCT

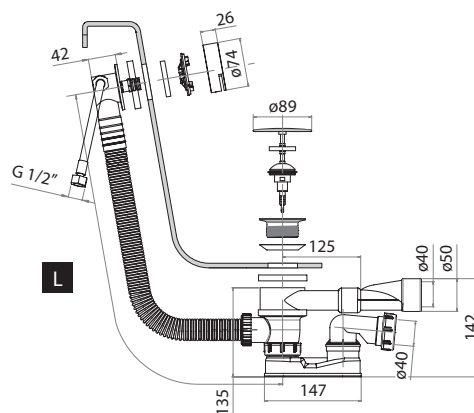

Colonna di scarico per vasca con aspirazione

- Bocca di erogazione "Fan" in ottone
- Tappo "Skip-up" \varnothing 89 mm in ottone
- Tubo corrugato flessibile
- Copertura troppo pieno in zama
- Sifone ribassato 64-B

Bath waste & overflow with suction

- Brass "Fan" style water spout
- \varnothing 89 mm "Skip-up" brass plug
- Flexible pipe
- Overflow cover in Zamak
- Low siphon 64-B



Imballo - Pack QxC QxB
Cod 1 12 216

L

Cod

cm

SK134-SCT.01	45-80	✓
SK134-SCT-1.01	81-125	✓

CRT • CRQ • CRD





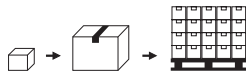





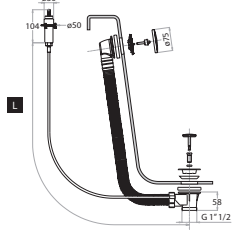

Colonna di scarico per vasca in polipropilene con comando di apertura/chiusura rotativo remoto a bordo vasca
 Bath pop-up waste & overflow in polypropylene with open/close rotary control over bathtub deck

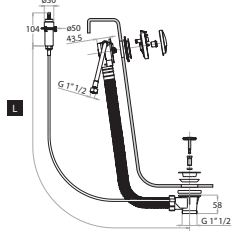
Option

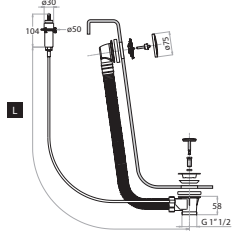

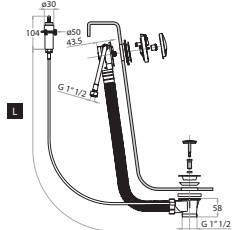
Imballo - Pack QxC QxB
 Cod 1 10 260

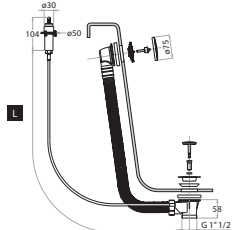

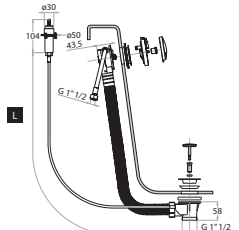
			Cod	L cm	
 <p>∅ 40</p>  	CRT10.01	45-55	✓		
	CRT10-1.01	56-65	✓		
	CRT10-2.01	70-80	✓		
	CRT10-3.01	81-90	✓		
 <p>∅ 40</p> <p>Bocca di erogazione al troppo pieno "Minimal Flat" "Minimal Flat" water outlet spout</p>  	CRT20.01	45-55	✓		
	CRT20-1.01	56-65	✓		
	CRT20-2.01	70-80	✓		
	CRT20-3.01	81-90	✓		
 <p>□ 30</p> <p>□ 45</p>  	CRQ10.01	45-55	✓		
	CRQ10-1.01	56-65	✓		
	CRQ10-2.01	70-80	✓		
	CRQ10-3.01	81-90	✓		
 <p>□ 30</p> <p>□ 45</p> <p>Bocca di erogazione al troppo pieno "Minimal Flat" "Minimal Flat" water outlet spout</p>  	CRQ20.01	45-55	✓		
	CRQ20-1.01	56-65	✓		
	CRQ20-2.01	70-80	✓		
	CRQ20-3.01	81-90	✓		
 <p>□ 30</p> <p>□ 45</p>  	CRD10.01	45-55	✓		
	CRD10-1.01	56-65	✓		
	CRD10-2.01	70-80	✓		
	CRD10-3.01	81-90	✓		
 <p>□ 30</p> <p>□ 45</p> <p>Bocca di erogazione al troppo pieno "Minimal Flat" "Minimal Flat" water outlet spout</p>  	CRD20.01	45-55	✓		
	CRD20-1.01	56-65	✓		
	CRD20-2.01	70-80	✓		
	CRD20-3.01	81-90	✓		

180

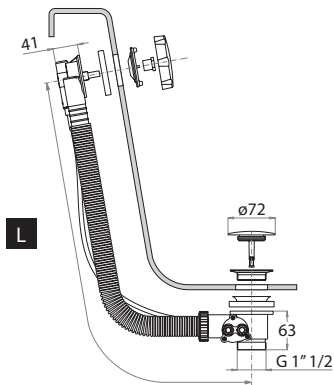

Colonna di scarico per vasca in polipropilene per vasche idromassaggio

- Trasmissione con movimento a cremagliera
- Bath pop-up waste & overflow in polypropylene for hydromassage bathtubs
- Rack and pinion drive system

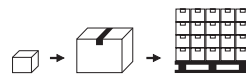

Imballo - Pack QxC QxB
Cod 1 20 260

		Cod	L cm	●	●	● ● ●	● ● ● ●	● ● ● ● ●	● ● ● ● ● ●
				.01	.16	.33 .35 .43	.25 .26 .38 .40	.12	
	180-__	45-55	✓	✓	✓		✓	✓	
	180-1-__	56-65	✓	✓	✓		✓	✓	
	180-2-__	70-80	✓	✓	✓		✓	✓	
	180-3-__	81-90	✓	✓	✓		✓	✓	
	180-A-__	45-55	✓		✓		✓	✓	
	180-A-1-__	56-65	✓		✓		✓	✓	
	180-A-2-__	70-80	✓		✓		✓	✓	
	180-A-3-__	81-90	✓		✓		✓	✓	
	180-L-__	45-55	✓	✓	✓		✓	✓	
	180-L-1-__	56-65	✓	✓	✓		✓	✓	
	180-L-2-__	70-80	✓	✓	✓		✓	✓	
	180-L-3-__	81-90	✓	✓	✓		✓	✓	
	180-M-__	45-55	✓	✓	✓		✓	✓	
	180-M-1-__	56-65	✓	✓	✓		✓	✓	
	180-M-2-__	70-80	✓	✓	✓		✓	✓	
	180-M-3-__	81-90	✓	✓	✓		✓	✓	
	180-MA-__	45-55	✓		✓		✓	✓	
	180-MA-1-__	56-65	✓		✓		✓	✓	
	180-MA-2-__	70-80	✓		✓		✓	✓	
	180-MA-3-__	81-90	✓		✓		✓	✓	
	180-PLUS-__	45-55	✓	✓	✓		✓	✓	
	180-PLUS-1-__	56-65	✓	✓	✓		✓	✓	
	180-PLUS-2-__	70-80	✓	✓	✓		✓	✓	
	180-PLUS-3-__	81-90	✓	✓	✓		✓	✓	

Differenti lunghezze fino a 125 cm
Lengths available up to 125 cm

105-H

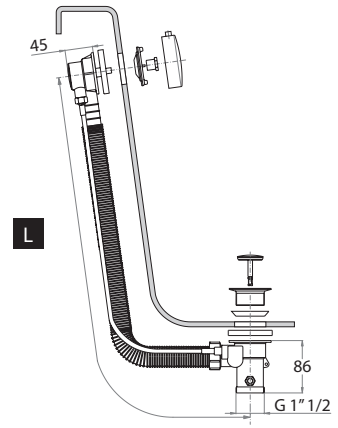

Colonna di scarico con doppio drenaggio per vasche idromassaggio

- Trasmissione con movimento "Eccentric"
- Bath pop-up waste & overflow with two inlet pump drains for hydromassage bathtubs
- "Eccentric" drive system



Imballo - Pack

Cod 1

		L										
Cod		cm	.01	.16	.33	.35	.43	.25	.26	.38	.40	.12
	105-H-__	45-55	✓	✓		✓				✓		✓
	105-H-1-__	56-65	✓	✓		✓				✓		✓
	105-H-2-__	70-80	✓	✓		✓				✓		✓
	105-H-3-__	81-90	✓	✓		✓				✓		✓
	105-H-A-__	45-55	✓			✓				✓		✓
	105-H-A-1-__	56-65	✓			✓				✓		✓
	105-H-A-2-__	70-80	✓			✓				✓		✓
	105-H-A-3-__	81-90	✓			✓				✓		✓
	105-H-L-__	45-55	✓	✓		✓				✓		✓
	105-H-L-1-__	56-65	✓	✓		✓				✓		✓
	105-H-L-2-__	70-80	✓	✓		✓				✓		✓
	105-H-L-3-__	81-90	✓	✓		✓				✓		✓
	105-H-M-__	45-55	✓	✓		✓				✓		✓
	105-H-M-1-__	56-65	✓	✓		✓				✓		✓
	105-H-M-2-__	70-80	✓	✓		✓				✓		✓
	105-H-M-3-__	81-90	✓	✓		✓				✓		✓
	105-H-MA-__	45-55	✓			✓				✓		✓
	105-H-MA-1-__	56-65	✓			✓				✓		✓
	105-H-MA-2-__	70-80	✓			✓				✓		✓
	105-H-MA-3-__	81-90	✓			✓				✓		✓
	105-H-PLUS-__	45-55	✓	✓		✓				✓		✓
	105-H-PLUS-1-__	56-65	✓	✓		✓				✓		✓
	105-H-PLUS-2-__	70-80	✓	✓		✓				✓		✓
	105-H-PLUS-3-__	81-90	✓	✓		✓				✓		✓

SK52

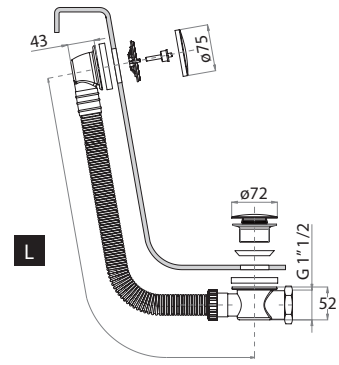















Colonna per vasca con scarico laterale

- Sistema di comando "Skip-up" con "QuikFix"
- Tubo di troppo pieno flessibile

Bath pop-up waste & overflow with lateral drain-pipe

- "Skip-up" plug system with "QuikFix"
- Flexible overflow pipe

Imballo - Pack			
Cod	1	QxC 20	QxB 260

	Cod	L cm										
 ø 72 Brass	SK52._ _	45-80	✓	✓		✓				✓		✓
	SK52-1._ _	81-125	✓	✓		✓				✓		✓
 ø 72 ABS	SK52-A._ _	45-80	✓			✓				✓		✓
	SK52-A-1._ _	81-125	✓			✓				✓		✓



AL200

Sifone ottone in tubo 1" 1/4
• Per lavabo
1" 1/4 brass washbasin p-trap

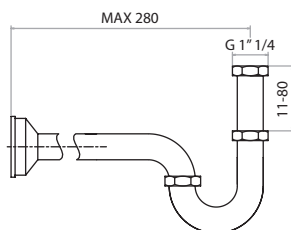

Cod

AL200.01	✓
----------	---

AL220

Sifone ottone a bottiglia 1" 1/4
• Per lavabo
1" 1/4 brass washbasin bottle trap

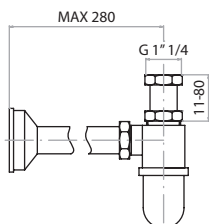

Cod									
AL220.01._ _	✓		✓				✓		✓

AL230

Sifone ottone 1" 1/4
• Per bidet
• Ispezionabile
1" 1/4 brass bidet p-trap
• Inspectable

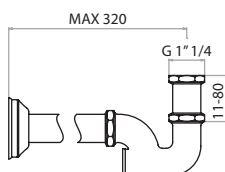

Cod

AL230.01	✓
----------	---

AL240

Sifone ottone 1" 1/4
• Per bidet
• Ispezionabile
1" 1/4 brass bidet p-trap
• Inspectable

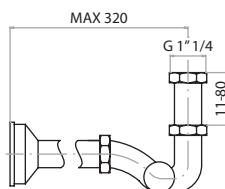

Cod

AL240.01	✓
----------	---

AL600

Sifone 1" 1/4 in polipropilene

- Per lavabo
- 1" 1/4 polypropylene washbasin bottle trap

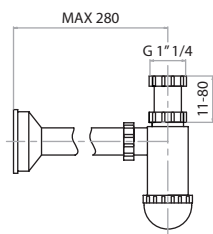

Cod

AL600	✓
-------	---

AL070

Rubinetto regolazione sottolavabo

- 1/2" x 3/8" con calotta e rosone
- 1/2" x 3/8" service angle valve with waterflow regulator

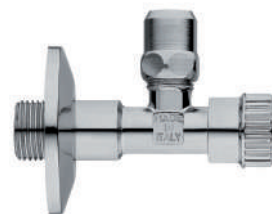
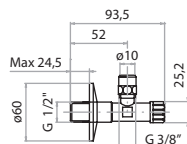

Cod

AL070.01	✓
----------	---

AL075

Rubinetto regolazione sottolavabo

- 1/2" x 1/2" con rosone
- 1/2" x 1/2" service angle valve with waterflow regulator

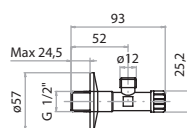

Cod

AL075.01	✓
----------	---

AL080

Rubinetto regolazione sottolavabo

- 1/2" x 3/8" con filtro, calotta e rosone
- 1/2" x 3/8" service angle valve with waterflow regulator and filter

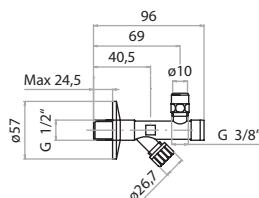

Cod

AL080.01	✓
----------	---

AL085

Rubinetto regolazione sottolavabo

- 1/2" x 1/2" con filtro, snodo, calotta e rosone
- 1/2" x 3/8" service angle valve with waterflow regulator and filter

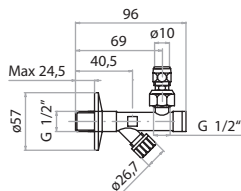

Cod

AL085.01	✓
----------	---

AL090

Rubinetto a sfera per lavatrice

- 1/2" x 3/4"
- 1/2" x 3/4" service ball valve

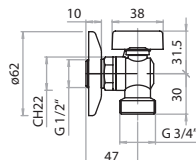

Cod

AL090.01	✓
----------	---

AL095

Rubinetto sottolavabo

- Con rosone e calotta 3/8"
- Attacco a muro 1/2", attacco sottolavabo per tubo \varnothing 10 mm e uscita attacco lavatrice 3/4"
- 1/2" x 3/4" service angle valve with additional \varnothing 10 mm outlet. Double waterflow regulator

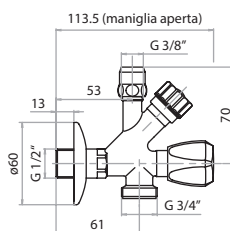

Cod

AL095.01	✓
----------	---

AL040

Distanziale per lavabo \varnothing 60 x 48 mm

H 30 mm ABS cromato

\varnothing 60 x 48 mm H 30 mm ABS chromed spacer for washbasin

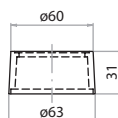

Cod

AL040.01	✓
----------	---

AL050

Intercalare per scarico lavabo con troppo pieno
ABS cromo
ø 70 mm ABS plastic spacer with overflow for
washbasin

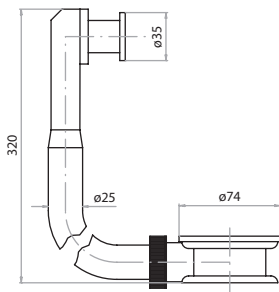

Cod

AL050.01	✓
----------	---



AL051

Intercalare per scarico lavabo con troppo pieno
in ABS bianco con griglia cromata
ø 70 mm white ABS plastic spacer with overflow
for washbasin, comes with chrome grate

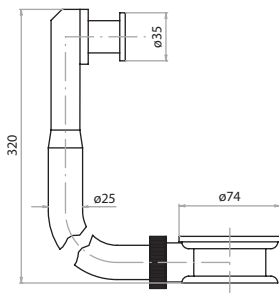

Cod

AL051.01	✓
----------	---



ALFT10

Filtro removibile per scarico universale
Removable filter for universal waste

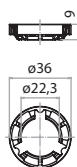

NEW

Cod

ALFT10	✓
--------	---



AL060

Prolunga piletta 1" 1/4 L. 50 mm
1" 1/4 x 50 mm extension for washbasin drain



Cod

AL060.01	✓
----------	---



170

Snodino doppio in plastica
Plastic double joint

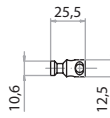

Cod

170	✓
-----	---

172

Snodino doppio in ottone
Brass double joint

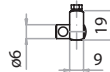

Cod

172	✓
-----	---

174

Snodino semplice in ottone
Brass single joint



Cod

174	✓
-----	---

091

Centralino bidet cromo asta 4x36 mm, pomolo ABS
ø 14 mm e snodino semplice
Drain control for central bidet. Complete in chrome
brass

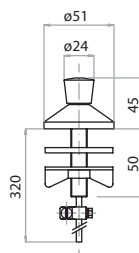

Cod

091	✓
-----	---

56-B

Sifone fuso in ottone per vasca a vista

- Completo di curva a pavimento e rosone
- P-trap for exposed bathtubs with vertical outlet

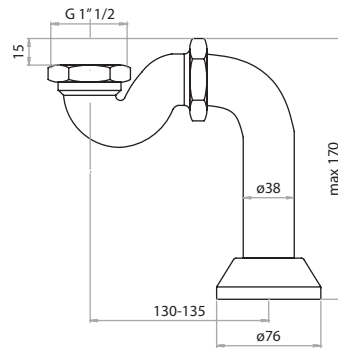

Cod

56-B.01



52B

Codolo diritto in ottone per vasca a vista

- Completo di rosone
- Straight tailpiece for exposed bathtubs

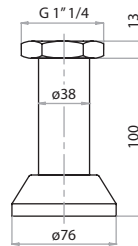

Cod

52B.01



55

Sifone ottone con dado

ø 38 mm brass trap with 1" 1/2 nut and seal

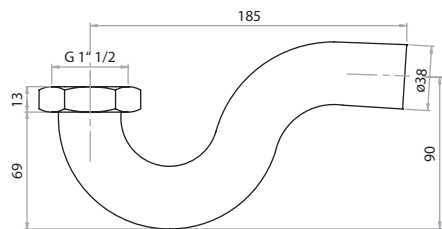

Cod

55



56

Sifone fuso

ø 40 mm - brass casted trap and extension pipe with 1" 1/2 nut and seal

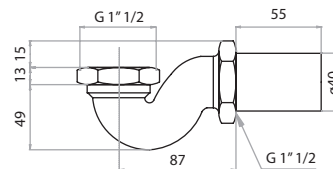

Cod

56



56-GA

Sifone fuso g.a. S/term.
ø 40 mm brass casted trap with 1" 1/2 male
connection 1" 1/2 nut and seal

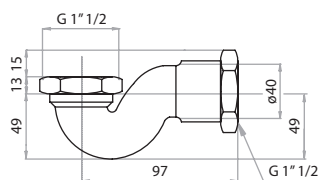

Cod

56-GA	✓
-------	---

52

Codolo curvo ottone con dado G 1" 1/2
ø 38 mm brass curved pipe connection
with 1" 1/2 nut and seal

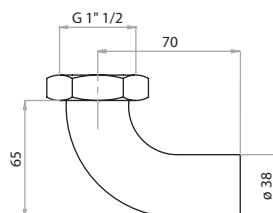

Cod

52	✓
----	---

52-TP

Codolo ottone diritto cm 7 con calotta
ø 38 mm straight tail piece with 1" 1/2 nut
and seal
Length 70 mm

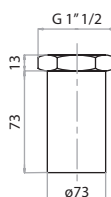

Cod

52-TP	✓
-------	---

ST40

Tubo corrugato estensibile
• Con terminale: ø 40 mm
ø 40 mm outlet terminal, polypropylene plastic
flexible hose

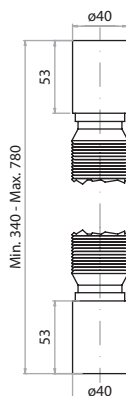

Cod

ST40	✓
------	---

52-P

Codolo curvo plastica 1" 1/2
ø 40 mm peh polyethylene plastic curved pipe
connection with 1" 1/2 nut and seal

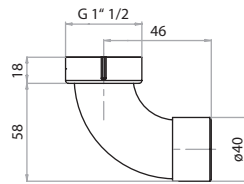

Cod

52-P	✓
------	---

63-A **NF**

Sifone in ABS ribassato ø 40 - 50 mm
ø 40 - 50 mm outlet terminal, ABS plastic reduced
height p-trap. Rotating joint. 1" 1/2 nut and seal

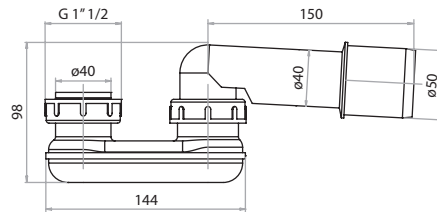

Cod

63-A	✓
------	---

64-B **NF**

Sifone in polipropilene ribassato 1" 1/2
ø 40 mm outlet terminal, polypropylene
p-trap. Rotating joint. 1" 1/2 nut and seal for
both outlets

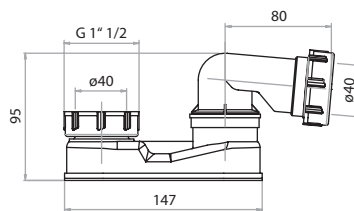

Cod

64-B	✓
------	---

ST45

Curva a 45° con terminale ø 40 - 50 mm
• Sifone con calotta e guarnizione
ø 40 - 50 mm outlet terminal ABS plastic 45° curve

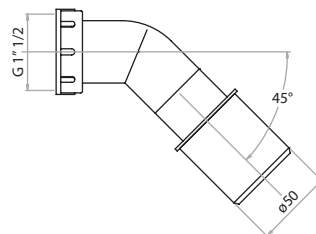

Cod

ST45	✓
------	---

RT110

Raccordo a "T" in ABS per art. 110
ø 38 mm ABS plastic "T" connection.
For use with product 110-N

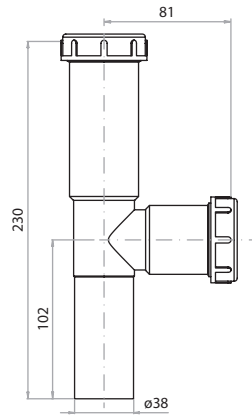

Cod

RT110	✓
-------	---

AV010

Distanziale per vasca ø 70 mm H10 mm in PP
con guarnizione
ø 70 mm H10 mm polypropylene spacer
with gasket for bathtub

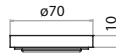

Cod

AV010	✓
-------	---

315

Passo rapido incasso da 3/4"
Concealed manual wall flush valve.
Easy-turn hand lever. 3/4" back inlet urinal fixture

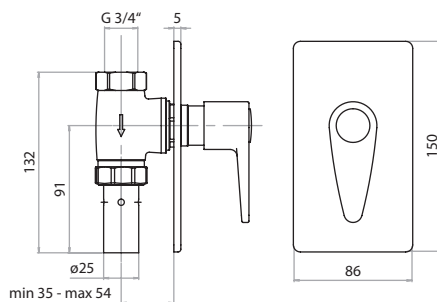

Cod

315.01	✓
--------	---

316

Passo rapido incasso da 1"
Concealed manual wall flush valve.
Easy-turn hand lever. 1" back inlet urinal fixture

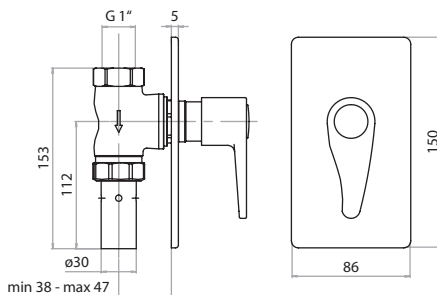

Cod

316.01	✓
--------	---

320

Passo rapido esterno da 3/4"
Exposed manual wall flush valve. Easy-turn
hand lever. 3/4" back inlet urinal fixture

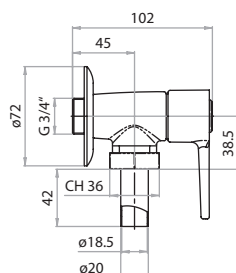

Cod

320.01	✓
--------	---

321

Passo rapido esterno da 1"
Exposed manual wall flush valve. Easy-turn hand
lever. 1" back inlet urinal fixture

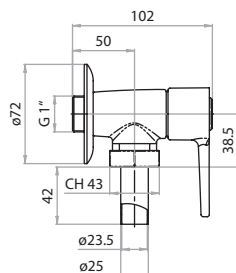

Cod

321.01	✓
--------	---

350

Saracinesca incasso 3/4" completa di cappuccio e rosone
Concealed 3/4" bathroom shut-off valve.
Complete with chrome cap and cover

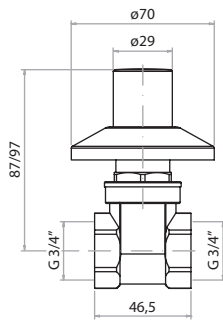

Cod

350.01	✓
--------	---

VIT001

Vitone passo rapido incasso 3/4"
Replacement valve for 3/4" concealed manual
wall flush valve

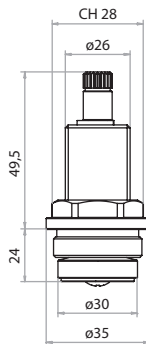

Cod

VIT001	✓
--------	---

VIT002

Vitone passo rapido incasso 1"
Replacement valve for 1" concealed manual
wall flush valve

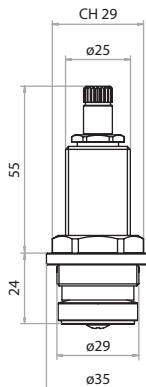

Cod

VIT002	✓
--------	---

VIT003

Vitone passo rapido esterno 3/4"
Replacement valve for 3/4" exposed manual
wall flush valve

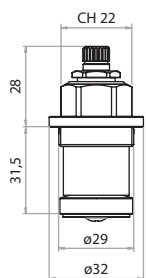

Cod

VIT003	✓
--------	---

VIT004

Vitone prolungato 30 mm incasso 1"
Extension (extended 30 mm) valve for 1"
concealed manual wall flush valve

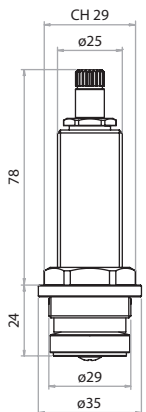

Cod

VIT004	✓
--------	---

PR315

Prolunga 20 mm per vitone passo rapido incasso 3/4"
20 mm extension for concealed manual wall flush
valve

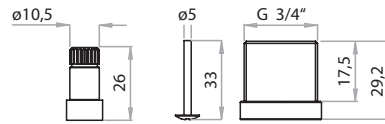

Cod

PR315.01	✓
----------	---



SKN30

Tappo ø 63 mm in **ottone** con meccanismo a pressione
 "Skip-up 2.0" per piletta lavabo
 ø 63 mm **brass** "Skip-up 2.0" plug for washbasin drain

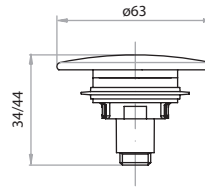

Cod										PVD Lucido Glossy	PVD Spazzolato Brushed
SKN30._.	✓		✓			✓			✓	✓	✓

SKN30B

Tappo ø 63 mm in **ottone** con meccanismo a pressione
 "Skip-up 2.0" sistema "QuikFix" per piletta lavabo
 "QuikFix" system ø 63 mm **brass** "Skip-up 2.0" plug for washbasin drain

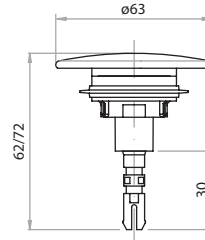

Cod										PVD Lucido Glossy	PVD Spazzolato Brushed
SKN30._B	✓		✓			✓			✓	✓	✓

SKN30SA

Tappo ø 63 mm in **ottone** versione sempre aperto per piletta
 lavabo
 ø 63 mm **brass** free-flow plug for washbasin drain

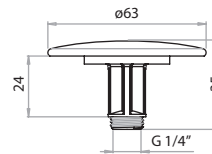

Cod										PVD Lucido Glossy	PVD Spazzolato Brushed
SKN30._SA	✓		✓			✓			✓	✓	✓

SKN30SAB

Tappo ø 63 mm in **ottone** versione sempre aperto
 sistema "QuikFix" per piletta lavabo
 "QuikFix" system ø 63 mm **brass** free-flow plug for washbasin drain

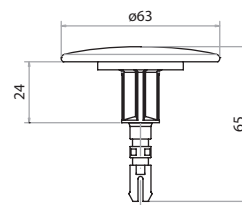

Cod										PVD Lucido Glossy	PVD Spazzolato Brushed
SKN30._SAB	✓		✓			✓			✓	✓	✓

SKN31

Tappo ø 70 mm in **ceramica** con meccanismo a pressione "Skip-up 2.0" per piletta lavabo
ø 70 mm "Skip-up 2.0" **ceramic** plug for washbasin drain

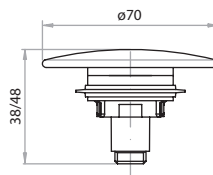

Cod

SKN31	✓
-------	---

SKN31B

Tappo ø 70 mm in **ceramica** con meccanismo a pressione "Skip-up 2.0" sistema "QuikFix" per piletta lavabo
"QuikFix" system ø 70 mm "Skip-up 2.0" **ceramic** plug for washbasin drain

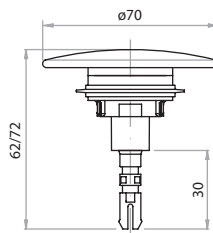

Cod

SKN31B	✓
--------	---

SKN31SA

Tappo ø 70 mm in **ceramica** versione sempre aperto per piletta lavabo
ø 70 mm **ceramic** free-flow plug for washbasin drain

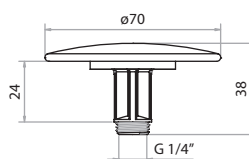

Cod

SKN31SA	✓
---------	---

SKN31SAB

Tappo ø 70 mm in **ceramica** versione sempre aperto sistema "QuikFix" per piletta lavabo
"QuikFix" system ø 70 mm **ceramic** free-flow plug for washbasin drain

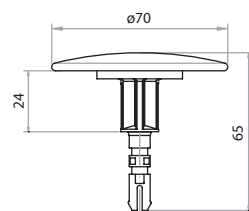

Cod

SKN31SAB	✓
----------	---

SKN32

Tappo ø 72 mm in **Corian®** con meccanismo a pressione "Skip-up 2.0" per piletta lavabo
ø 72 mm "Skip-up 2.0" **Corian®** plug for washbasin drain

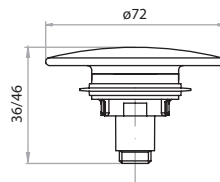

Cod

SKN32	✓
-------	---

SKN32B

Tappo ø 72 mm in **Corian®** con meccanismo a pressione "Skip-up 2.0" sistema "QuikFix" per piletta lavabo
"QuikFix" system ø 72 mm "Skip-up 2.0" **Corian®** plug for washbasin drain

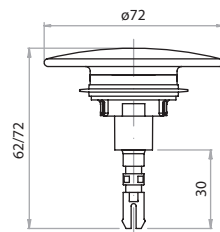

Cod

SKN32B	✓
--------	---

SKN32SA

Tappo ø 72 mm in **Corian®** versione sempre aperto per piletta lavabo
ø 72 mm **Corian®** free-flow plug for washbasin drain

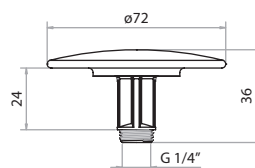

Cod

SKN32SA	✓
---------	---

SKN32SAB

Tappo ø 72 mm in **Corian®** versione sempre aperto sistema "QuikFix" per piletta lavabo
"QuikFix" system ø 72 mm **Corian®** free-flow plug for washbasin drain

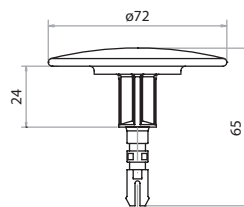

Cod

SKN32SAB	✓
----------	---

SKN30Z

Tappo ø 63 mm in **zama** con meccanismo a pressione "Skip-up 2.0" per piletta lavabo
ø 63 mm **zamak** "Skip-up 2.0" plug for washbasin drain

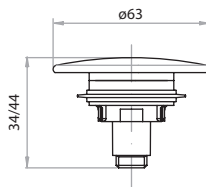

Cod

SKN30.01Z	✓
-----------	---

SKN30ZB

Tappo ø 63 mm in **zama** con meccanismo a pressione "Skip-up 2.0" sistema "QuikFix" per piletta lavabo
"QuikFix" system ø 63 mm **zamak** "Skip-up 2.0" plug for washbasin drain

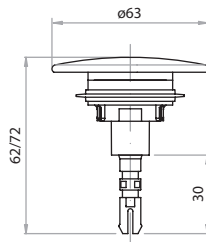

Cod

SKN30.01ZB	✓
------------	---

SKN30P

Tappo ø 62 mm in ABS con **copertura inox**, meccanismo a pressione "Skip-up 2.0" per piletta lavabo
ø 62 mm ABS **INOX covering** "Skip-up 2.0" plug for washbasin drain

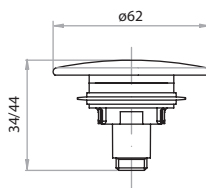

NEW

Cod

SKN30P.01	✓
-----------	---

SKN30PSA

Tappo ø 62 mm in ABS con **copertura inox**, versione sempre aperto per piletta lavabo
ø 62 mm ABS **INOX covering** free-flow plug for washbasin drain

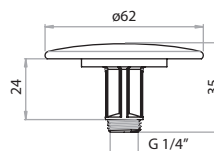

NEW

Cod

SKN30P.01SA	✓
-------------	---

SKN30PB

Tappo ø 62 in polipropilene ricoperto in acciaio con meccanismo a pressione "Skip-up 2.0" sistema "QuikFix" per piletta lavabo
"QuikFix" system ø 62 mm "Skip-up" stainless steel wrapped polypropylene plug for washbasin drain

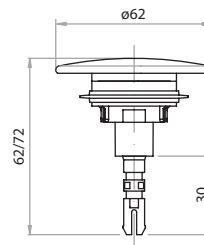

NEW

Cod

SKN30P.01B	✓
------------	---

SKN30PSAB

Tappo ø 62 in polipropilene ricoperto in acciaio versione sempre aperto sistema "QuikFix" per piletta lavabo
"QuikFix" system ø 62 mm "Skip-up" stainless steel wrapped polypropylene plug for washbasin drain

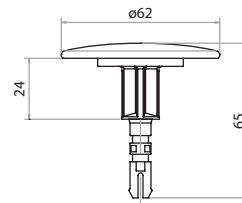

NEW

Cod

SKN30P.01SAB	✓
--------------	---

SKN30-INOX

Tappo ø 63 mm in **acciaio inox**, meccanismo a pressione "Skip-up 2.0" per piletta lavabo
ø 63 mm **INOX covering** "Skip-up 2.0" plug for washbasin drain

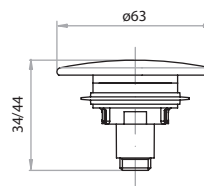

INOX

NEW

Cod

SKN30-INOX	✓
------------	---

SKN30-INOXSA

Tappo ø 63 mm in **acciaio inox**, meccanismo a pressione "Skip-up 2.0" sistema "QuikFix" per piletta lavabo
"QuikFix" system ø 63 mm **INOX covering** "Skip-up 2.0" plug for washbasin drain

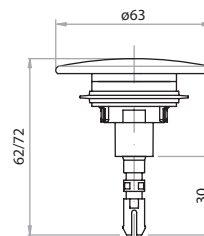

INOX

NEW

Cod

SKN30-INOXSA	✓
--------------	---

SK5

Tappo ø 65 in polipropilene ricoperto in acciaio con meccanismo a pressione "Skip-up" per piletta lavabo
ø 65 mm "Skip-up" stainless steel wrapped polypropylene plug

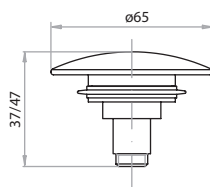

Cod

SK5	✓
-----	---

TS100P

Tappo SNAP ø 40 mm con copertura in acciaio inox
ø 40 mm SNAP plug with stainless steel covering

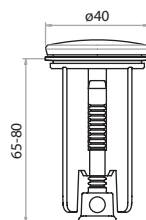

Cod

TS100P.01	✓
-----------	---

TS100

Tappo SNAP ø 40 mm con copertura in ottone
ø 40 mm SNAP plug with brass covering

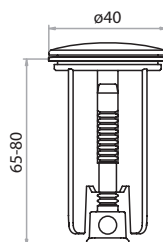

Cod										PVD Lucido Glossy	PVD Spazzolato Brushed
TS100._._	✓	✓	✓	✓	✓	✓	✓	✓	✓	✓	✓

TS160

Tappo SNAP ø 63 mm con copertura in ottone
ø 63 mm SNAP plug with brass covering

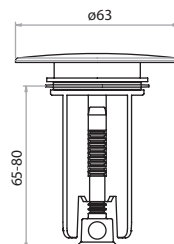

Cod										PVD Lucido Glossy	PVD Spazzolato Brushed
TS160._._	✓	✓	✓	✓	✓	✓	✓	✓	✓	✓	✓

TS175

Tappo SNAP ø 70 mm con copertura in **ceramica**
ø 70 mm SNAP plug with **ceramic** covering

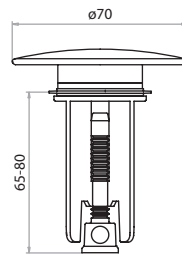

Cod

TS175	✓
-------	---

TS185

Tappo SNAP ø 72 mm con copertura in **Corian®**
ø 72 mm SNAP plug with **Corian®** covering

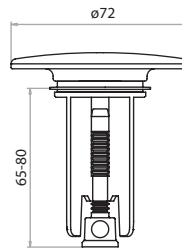

Cod

TS185	✓
-------	---

T007

Tappo ottone 1" 1/4
1" 1/4 brass plug

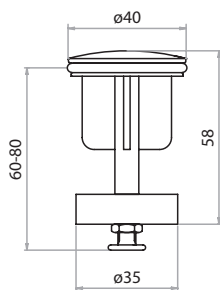

Cod										PVD Lucido Glossy	PVD Spazzolato Brushed
T007._ _	✓		✓			✓			✓	✓	✓

T007L

Tappo ottone 1" 1/4 con ali in plastica
1" 1/4 brass plug on plastic stem

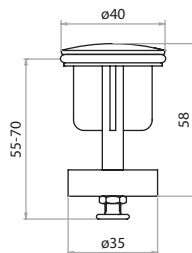

Cod										PVD Lucido Glossy	PVD Spazzolato Brushed
T007L._ _	✓		✓			✓			✓	✓	✓

T360

Tappo copripiletta in ottone 1" 1/4 con ali in plastica
1" 1/4 brass plug drain-cover on plastic stem

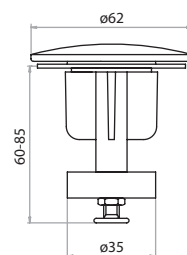







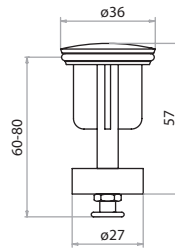

Cod										PVD Lucido Glossy	PVD Spazzolato Brushed
T360._ _	✓		✓			✓			✓	✓	✓

T002

Tappo ottone 1"
1" brass plug



Cod	 .01	 .33	 .35	 .43	 .25	 .26	 .38	 .40	 .12
T002._ _	✓		✓			✓			✓

T002P

Tappo in polipropilene ricoperto in acciaio 1"
1" stainless steel wrapped polypropylene plug

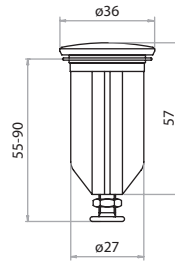

Cod

T002P.01	✓
----------	---

AL063

Distanziale lavabo ø 63 mm, H 13 mm per "ISY-SIPHON"
ø 63 mm H 13 mm washbasin spacer for "ISY-SIPHON"

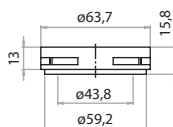

NEW

Cod

AL063	✓
-------	---

ASF800

Filtro per "ISY-SIPHON" serie AL800
Filter for AL800 series "ISY-SIPHON"

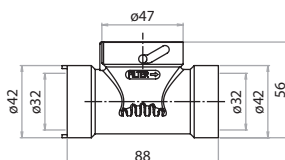

NEW

Cod

ASF800	✓
--------	---

ASF830

Filtro per "ISY-SIPHON" serie AL830
Filter for AL830 series "ISY-SIPHON"

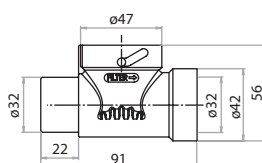

NEW

Cod

ASF830	✓
--------	---

GU800

Guarnizione per "ISY-SIPHON"
Gasket for "ISY-SIPHON"

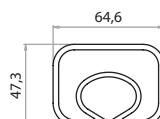

NEW



Cod

GU800	✓
-------	---

590

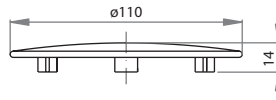
Tappo ø 110 mm in ABS per serie ST6590N
ø 110 mm ABS plug for ST6590N series





Cod	 .01	 .33	 .43
590._ _	✓	✓	

595

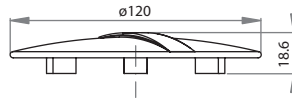
Tappo ø 120 mm in ABS per serie ST6590
ø 120 mm ABS plug for ST6590 series



Cod	 .01	 .33	 .43
595._ _	✓	✓	

ASSIF6590W

Sifone interno per serie ST6590
Internal siphon for ST6590 series

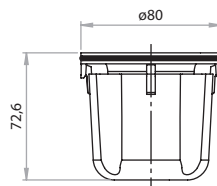

Cod

ASSIF6590W	✓
------------	---

ASSIF6590

Sifone interno per serie ST6590A
Internal siphon for ST6590A series

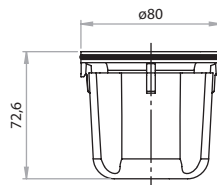

Cod

ASSIF6590	✓
-----------	---

75

Maniglia "BILLY" ABS
ABS plastic "BILLY" style knob

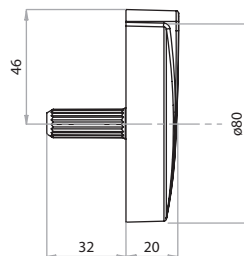

Cod

75.01	✓
-------	---

60

Maniglia zama "6 gole"
"6 groove" zamak control knob

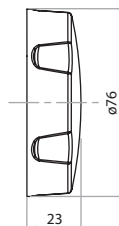

Cod

60.01	✓
-------	---

60-OT

Maniglia ottone "6 gole"
"6 groove" brass control knob

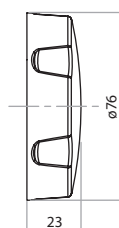

Cod	.01	.16	.33	.35	.43	.25	.26	.38	.40	.12	PVD Lucido Glossy	PVD Spazzolato Brushed
60-OT._._	✓	✓	✓	✓	✓	✓	✓	✓	✓	✓	✓	✓

60-M

Maniglia "Minimal" ottone
"Minimal" style brass control knob

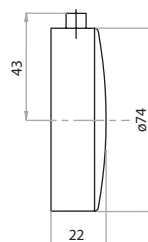

Cod	.01	.16	.33	.35	.43	.25	.26	.38	.40	.12	PVD Lucido Glossy	PVD Spazzolato Brushed
60-M._._	✓	✓	✓	✓	✓	✓	✓	✓	✓	✓	✓	✓

60-A

Maniglia "6 gole" in ABS

- Con fissaggio a scatto
- "6 groove" ABS control knob with "snap-in" fixing system

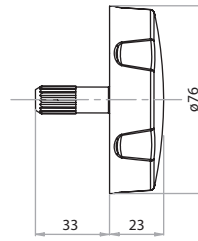

Cod	.01	.33	.35	.43	.25	.26	.38	.40	.12
60-A._._	✓		✓				✓		✓

60-M-AB

Maniglia "Minimal" in ABS

- Con fissaggio a scatto
- "Minimal" style ABS control knob

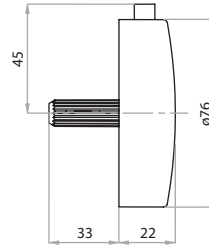

Cod	.01	.33	.35	.43	.25	.26	.38	.40	.12
60-M-AB._._	✓		✓				✓		✓

40

Copertura in zama per modello SK

Minimal brass overflow cover for use with SK products

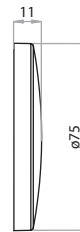

Cod

40.01	✓
-------	---

41

Copertura in zama per erogazione SK

- Gambo ø 9 mm, h. 33 mm, fresato e O-Ring

Minimal brass overflow cover. For use with product: SK tub filler

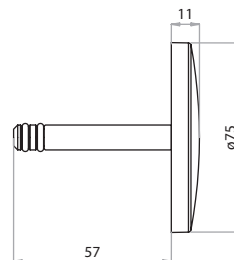

Cod

41.01	✓
-------	---

65

Bocca di erogazione in ottone completa di aeratore
Brass aerator tub filler

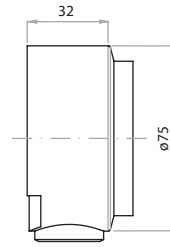

Cod										PVD Lucido Glossy	PVD Spazzolato Brushed
65._ _	✓		✓			✓			✓	✓	✓

65-A

Bocca di erogazione "Clean" in ABS con griglia rompigitto
"Clean" water spout in ABS with flow regulator grid

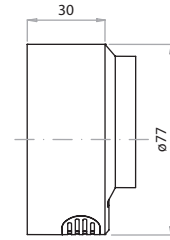

Cod									
65-A._ _	✓		✓			✓			✓

34

Bocca di erogazione in ottone modello "Fan"
Brass "Fan" style water spout



Cod											PVD Lucido Glossy	PVD Spazzolato Brushed
34._ _	✓	✓		✓			✓			✓	✓	✓

45

Copertura erogazione ABS "liscia"
Smooth ABS water spout cover

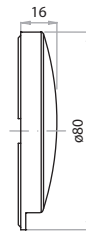

Cod	.01	.33	.35	.43	.25	.26	.38	.40	.12
45._ _	✓		✓			✓			✓

46

Copertura erogazione ABS
ABS water spout cover

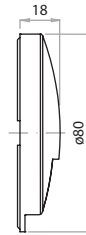

Cod	.01	.33	.35	.43	.25	.26	.38	.40	.12
46._ _	✓		✓			✓			✓

ROS-151

Rosone erogazione con ingranaggio completo
Water spout with complete gear

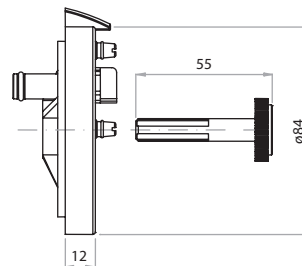

Cod	.01	.33	.35	.43	.25	.26	.38	.40	.12
ROS-151._ _	✓		✓			✓			✓

ROS-SK151

Rosone erogazione per versione SK
Water spout suitable for SK products

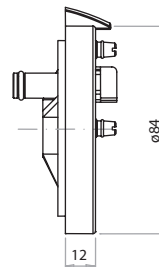

Cod	.01	.33	.35	.43	.25	.26	.38	.40	.12
ROS-SK151._ _	✓		✓			✓			✓

SK59-A

Tappo ø 72 mm ABS modello "Skip-up" con filetto
ø 72 mm "Skip-up" ABS plug

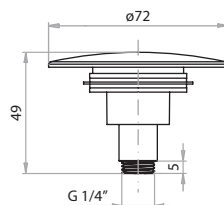

Cod	.01	.33	.35	.43	.25	.26	.38	.40	.12
SK59-A._.	✓		✓			✓			✓

SK59-AB

Tappo ø 72 mm ABS modello "Skip-up" sistema "QuikFix"
"QuikFix" system ø 72 mm "Skip-up" ABS plug

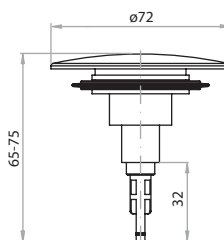

Cod	.01	.33	.35	.43	.25	.26	.38	.40	.12
SK59-A._.	✓		✓			✓			✓

SKN59-L

Tappo ø 72 mm ottone modello "Skip-up 2.0" con filetto
ø 72 mm "Skip-up" brass plug

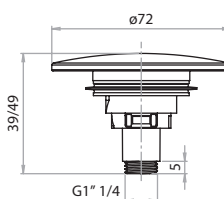

Cod	.01	.16	.33	.35	.43	.25	.26	.38	.40	.12	PVD Lucido Glossy	PVD Spazzolato Brushed
SKN59-L._.	✓	✓		✓			✓			✓	✓	✓

SKN59-LB

Tappo ø 72 mm ottone modello "Skip-up 2.0" sistema "QuikFix"
"QuikFix" system ø 72 mm "Skip-up" brass plug

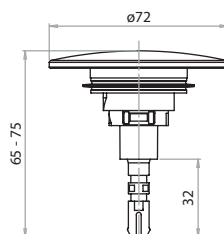

Cod	.01	.16	.33	.35	.43	.25	.26	.38	.40	.12	PVD Lucido Glossy	PVD Spazzolato Brushed
SKN59-L._.B	✓	✓		✓			✓			✓	✓	✓

SK59-SCT

Tappo ottone ø 89 mm per SK14-SCT, sistema "QuikFix"
 "QuikFix" system ø 89 mm brass plug for SK14-SCT

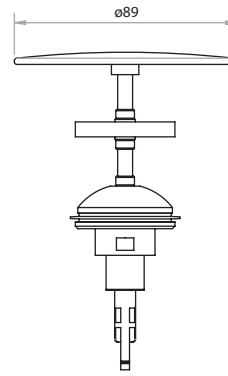

Cod

SK59-SCT.01	✓
-------------	---

59-UK

Tappo ø 72 mm ABS modello UNIKA con filtro
 ø 72 mm ABS UNIKA plug with filter

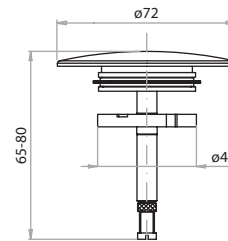

Cod

59-UK.01	✓
----------	---

59-A

Tappo ø 72 mm ABS anti-rottura
 ø 72 mm ABS anti-break plug

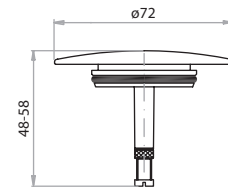

Cod				
59-A._._	✓	✓	✓	✓

59-L

Tappo ø 72 mm
 ø 72 mm brass plug

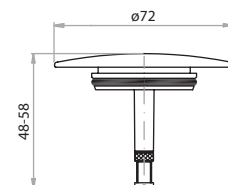

Cod						PVD Lucido Glossy	PVD Spazzolato Brushed
59-L._._	✓	✓	✓	✓	✓	✓	✓

59

Tappo ø 42 mm con vite e O-Ring
ø 42 mm brass plug

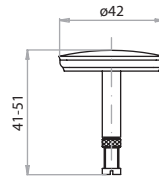

Cod	.01	.16	.33	.35	.43	.25	.26	.38	.40	.12	PVD Lucido Glossy	PVD Spazzolato Brushed
59._._	✓	✓	✓	✓	✓	✓	✓	✓	✓	✓	✓	✓

57A-UK

Piletta acciaio INOX "basket" UNIKA
Stainless steel deep waste flange with fixing screw

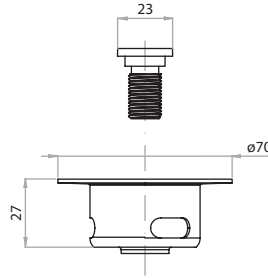

Cod	.01	.33	.35	.43	.25	.26	.38	.40	.12	PVD Lucido Glossy	PVD Spazzolato Brushed
57A-UK._._	✓	✓	✓	✓	✓	✓	✓	✓	✓	✓	✓

57-UK

Piletta ottone "basket" UNIKA
Brass deep waste flange with fixing screw

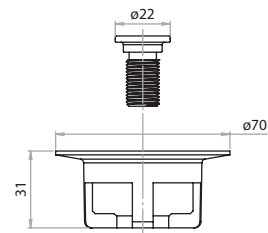

NEW

Cod	.01	.16	.33	.35	.43	.25	.26	.38	.40	.12	PVD Lucido Glossy	PVD Spazzolato Brushed
57-UK._._	✓	✓	✓	✓	✓	✓	✓	✓	✓	✓	✓	✓

SK58

Piletta ottone filetto G 1" 1/2
1" 1/2 brass waste flange

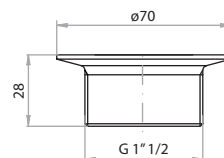

Cod	.01	.16	.33	.35	.43	.25	.26	.38	.40	.12	PVD Lucido Glossy	PVD Spazzolato Brushed
SK58._._	✓	✓	✓	✓	✓	✓	✓	✓	✓	✓	✓	✓

58

Piletta ottone
1" 1/2 brass waste flange

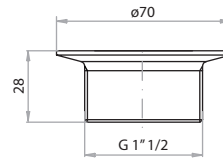

Cod											PVD Lucido Glossy	PVD Spazzolato Brushed
58._ _	✓	✓	✓			✓				✓	✓	✓

57

Piletta ottone bassa
Brass waste flange with fixing screw

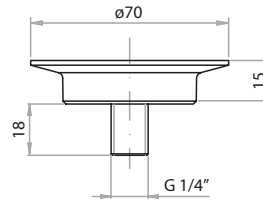

Cod											PVD Lucido Glossy	PVD Spazzolato Brushed
57._ _	✓	✓	✓			✓				✓	✓	✓

57-AC

Piletta acciaio inox ø 72 mm
Stainless steel waste flange with fixing screw

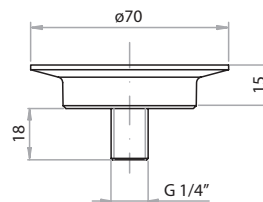

Cod										PVD Lucido Glossy	PVD Spazzolato Brushed
57-AC._ _	✓	✓			✓				✓	✓	✓

CGS

■ Condizioni generali di vendita

Le presenti Condizioni Generali di Vendita (d'ora in avanti «CGV») della società C.G.S. S.r.l. (d'ora in avanti «CGS») si applicano a qualsiasi ordine effettuato a CGS da parte di un Acquirente professionista (d'ora in avanti «l'Acquirente») per tutte le consegne effettuate in tutti i Paesi in cui CGS opera. Qualsiasi ordine di prodotti o di prestazioni di servizio comporta, quale condizione essenziale e determinante, l'accettazione senza riserve da parte dell'Acquirente delle presenti CGV che costituiscono la base della negoziazione commerciale, in conformità delle disposizioni degli articoli del Codice del commercio in vigore nei vari Paesi, e la relativa rinuncia da parte dell'Acquirente a qualsiasi altra condizione contraria, a tutte le condizioni generali o particolari dell'Acquirente, incluse le eventuali condizioni di acquisto e gli ordini di acquisto, i contratti di riferimento e i contratti di esercizio commerciale, ogni volta che tali condizioni e/o contratti non abbiano ricevuto il preventivo consenso scritto di CGS. La negoziazione commerciale tra CGS e l'Acquirente dovrà essere condotta nel reciproco rispetto degli interessi delle Parti con lealtà e buona fede. Le presenti CGV sono modificabili in qualsiasi momento, fermo restando che qualsiasi eventuale modifica sarà notificata all'Acquirente e che essa entrerà in vigore un (1) mese dal ricevimento della notifica.

PREZZO

I prezzi indicati nel presente Listino prezzi al pubblico sono indicativi e non vincolanti se non vengono confermati da CGS. Essi si intendono al netto delle imposte e sono espressi in Euro "franco fabbrica". Tale Listino prezzi annulla e sostituisce tutte le edizioni precedenti, fatti salvi errori ed omissioni. Il Listino prezzi al pubblico rappresenta lo strumento di riferimento più aggiornato. Eventuali errori di tale Listino prezzi al pubblico non costituiscono motivo di reclamo. Qualsiasi ordine effettuato comporta l'accettazione di tutte le condizioni di vendita riportate di seguito. CGS si riserva il diritto di aumentare i prezzi in qualsiasi momento, in particolare in caso di aumento dei costi di produzione legati ad un aumento del prezzo delle materie prime.

PRODOTTI

1. I prodotti oggetto delle presenti CGV sono definiti con riferimento al catalogo di CGS, il quale non può in alcun caso costituire documento contrattuale.
2. I prodotti sono fabbricati con la massima accuratezza possibile, fermo restando le tolleranze in uso nel settore in questione. CGS si riserva la possibilità di modificare in modo unilaterale le caratteristiche dei prodotti venduti in base ai miglioramenti raccomandati dai propri servizi, e questo senza obbligo da parte sua di modificare i prodotti consegnati in precedenza o i prodotti in corso d'ordine, e senza che le stampe, le descrizioni e le informazioni riportate a titolo pubblicitario sui documenti commerciali di CGS possano essere contestate all'azienda.

ORDINI

Gli ordini sono subordinati all'accettazione di CGS e si intendono subordinati alla totalità delle condizioni di vendita stabilite. Gli ordini si intendono accettati ai prezzi e alle condizioni in vigore alla data dell'ordine. Gli ordini e le modifiche comunicati verbalmente e per telefono dovranno essere confermati dal cliente tramite posta, fax o e-mail. Eventuali annullamenti potranno essere autorizzati soltanto previo benestare scritto di CGS, che si riserva di applicare le penali che ne potrebbero conseguire o si riserva il diritto di rifiutarli.

CGS si riserva il diritto di richiedere all'Acquirente il pagamento anticipato dell'ordine. L'ordine sarà considerato certo e definitivo soltanto successivamente all'incasso da parte di CGS del prezzo fatturato.

CONSEGNE / TRASPORTO / TRASFERIMENTO DEI RISCHI

1. Salvo se non diversamente specificato, la consegna sarà effettuata all'indirizzo indicato dall'Acquirente al momento dell'ordine. Indipendentemente dalla modalità di spedizione dei prodotti, e in deroga alla clausola di riserva di proprietà stabilita nelle CGV di cui in appresso, i rischi e pericoli sono trasferiti all'Acquirente al momento della consegna fisica delle merci al primo trasportatore. Se la spedizione subisce ritardi a causa del comportamento dell'Acquirente o per una causa indipendente dalla volontà di CGS, il trasferimento dei rischi avverrà al momento della comunicazione all'Acquirente di una notifica di fornitura dei prodotti.
2. I tempi di consegna, menzionati nella conferma dell'ordine, sono

forniti esclusivamente a titolo indicativo in funzione delle disponibilità dei prodotti e del trasporto, a meno che non venga espressamente menzionato che eventuali ritardi hanno natura tassativa.

3. I termini di consegna eventualmente accettati da CGS sono di pieno diritto sospesi in seguito a qualsiasi evento che esuli dal controllo di CGS e che provochi un ritardo nella consegna, ed in particolare in casi di forza maggiore, ossia qualsiasi evento indipendente dalla volontà di CGS o di uno dei suoi fornitori, prevedibile e inarrestabile, di qualsivoglia natura, catastrofe naturale, pandemia, intemperie, sabotaggio, embargo, sciopero, interruzione o ritardo nei trasporti o nell'approvvigionamento di materie prime, energia o componenti, incidenti delle macchine utensili, che ha l'effetto di rendere il contratto ineseguibile in modo temporaneo o definitivo. L'elenco dei casi di forza maggiore non è limitativo. CGS informerà l'Acquirente in caso di sopravvenienza di un evento di forza maggiore. In questo caso, i termini di consegna indicati saranno automaticamente prorogati in misura proporzionale. Qualora, nonostante i propri sforzi, CGS si trovi nell'impossibilità di consegnare le merci ordinate per cause di forza maggiore, CGS sarà esonerata dal proprio obbligo di consegna.
4. I ritardi di consegna non potranno dar luogo né a penali, né a risarcimenti, né ad annullamenti degli ordini, né a rifiuti di consegna, né tanto meno a sospensioni dei pagamenti delle fatture, salvo preventivo accordo scritto fornito da CGS, e questo nonostante l'esistenza di clausole contrarie nelle eventuali condizioni di acquisto dell'Acquirente. In ogni caso, soltanto il pregiudizio realmente patito dall'Acquirente, dimostrato e valutato, potrà essere oggetto di una domanda di risarcimento la quale dovrà, ad ogni modo, essere presentata soltanto previo accordo tra le parti. In caso di mancato accordo, la stima del pregiudizio subito sarà stabilita da un perito incaricato dal Tribunale del commercio di Novara, su richiesta della parte più diligente.
5. Qualsiasi modifica di un ordine che sopraggiunga in corso di esecuzione, anche se accettata da CGS, comporta una proroga del termine di consegna previsto secondo le modalità comunicate da CGS all'Acquirente.
6. Spetta all'Acquirente verificare i prodotti al momento del ricevimento ed esprimere immediatamente qualsiasi riserva utile secondo le condizioni previste nelle presenti CGV. Qualsiasi reclamo sarà preso in considerazione soltanto se la merce si trova ancora nel medesimo stato in cui è stata consegnata.

ESCLUSIONE DI PENALI

Nessuna penale di qualsivoglia natura potrà essere fatturata o detratta dall'Acquirente, da un saldo di prodotti, senza che CGS abbia potuto verificare la sussistenza della violazione e del pregiudizio invocati dall'Acquirente in forza degli articoli dei Codici del commercio in vigore nei vari Paesi in cui CGS opera, e senza che CGS abbia fornito il proprio preventivo consenso scritto al riguardo. A tal fine, l'Acquirente dovrà fornire a CGS tutti i documenti finalizzati a consentire un'analisi comparativa della violazione invocata e attestante il pregiudizio realmente patito. CGS disporrà di un termine sufficiente per analizzare i documenti inviati e informare l'Acquirente in merito al proprio accordo o disaccordo circa la violazione invocata e l'entità del risarcimento richiesto. Qualsiasi addebito diretto da parte dell'Acquirente in violazione delle presenti disposizioni sarà assimilato a un incidente di pagamento che autorizzerà CGS a rifiutare qualsiasi nuovo ordine di prodotti e a sospendere qualsiasi consegna in corso dopo averne dato notizia all'Acquirente, o a sospendere il saldo di ristorni e altri vantaggi finanziari.

CLAUSOLE DI RISERVA DI PROPRIETÀ

Le nostre vendite sono perfezionate alla consegna delle merci, tuttavia la proprietà sarà trasferita all'Acquirente soltanto successivamente al pagamento effettivo e completo della fattura. Il trasferimento dei rischi ha luogo al momento della consegna e l'Acquirente deve garantire le merci contro qualsiasi rischio, inclusi quelli di caso fortuito o di forza maggiore. L'Acquirente e il suo assicuratore rinunciano anticipatamente a qualsiasi ricorso nei confronti di CGS. CGS autorizza la rivendita del materiale consegnato prima del pagamento integrale del prezzo, ma senza per questo rinunciare all'esercizio del proprio diritto di proprietà.

DATI IDENTIFICATIVI DEL CLIENTE

Il cliente è responsabile di tutti i dati identificativi forniti a CGS come ad esempio: ragione sociale, sede legale, partita IVA insieme a tutti gli altri dati richiesti specificatamente dalla legislazione vigente. I dati del cliente, ai sensi delle leggi in vigore nei diversi Paesi in cui CGS opera, saranno

conservati ed elaborati ai fini dell'assolvimento degli obblighi di legge. Tutti gli altri utilizzi dovranno essere accettati dal cliente.

IMBALLAGGIO E SPEDIZIONE

Gli imballaggi sono preparati da personale specializzato. Il prezzo pattuito si intende comprensivo del normale imballo. Nel caso di richieste particolari da parte del committente, verrà stabilito un prezzo speciale in funzione del costo aggiuntivo sostenuto. Gli imballi non si ricevono di ritorno. Le merci viaggiano a rischio e pericolo del cliente. Il destinatario è tenuto a controllare le merci consegnate e a contestare tempestivamente ai trasportatori gli eventuali danni al ricevimento della merce e ad informare CGS (anche se questi sono stati scelti da CGS). Salvo accordi diversi, le spese di trasporto restano a carico del cliente.

PAGAMENTO E RITARDI

1. Ogni consegna successiva a un ordine dell'Acquirente dà luogo all'emissione di una fattura. Le fatture sono pagabili a CGS entro trenta (30) giorni dalla data della fattura, tramite bonifico bancario, salvo condizioni particolari concordate tra CGS e l'Acquirente. Tutti i pagamenti saranno effettuati al netto delle commissioni.
2. In caso di mancato pagamento alla scadenza, in forza degli articoli del Codice del commercio in vigore nei vari Paesi in cui CGS opera, saranno esigibili a pieno titolo e senza preavviso interessi di ritardo dal giorno successivo alla data di scadenza indicata sulla fattura fino al giorno del saldo completo.
3. In nessun caso i pagamenti dovuti a CGS potranno essere sospesi né essere oggetto di una qualsiasi riduzione o compensazione su iniziativa esclusiva dell'Acquirente, essendo indispensabile il preventivo benestare scritto di CGS, e ciò indipendentemente dalle eventuali disposizioni contrarie che potrebbero essere incluse nelle condizioni di acquisto dell'Acquirente.
4. In caso di ritardo o di mancanza di pagamento nonostante l'invio delle ingiunzioni, CGS si riserva il diritto, in relazione a qualsiasi ordine futuro, di esigere garanzie di pagamento nonché di esigere che la consegna della merce ordinata avvenga soltanto dietro pagamento integrale dell'ordine. Riguardo le ingiunzioni di pagamento restare senza effetto, CGS potrà chiedere la revoca della vendita, esigere il pagamento immediato delle merci consegnate, sospendere qualsiasi consegna e/o annullare qualsiasi ordine in corso fino al saldo completo di tutte le somme dovute. In caso di revoca, l'Acquirente dovrà rimborsare a CGS tutti i costi legati alla conclusione del contratto come anche il mancato guadagno. In caso di mancato pagamento totale o parziale anche soltanto di una scadenza, CGS potrà procedere al recupero delle merci vendute fatta salva la proprietà in forza delle disposizioni previste al pertinente paragrafo delle CGV.

RESPONSABILITÀ

Tutti gli articoli di nostra produzione sono accuratamente controllati. I danni provocati da un'errata installazione o un uso improprio non sono coperti dalla garanzia, salvo accordo specifico tra CGS e l'Acquirente. CGS non accetta resi della merce, se non preventivamente autorizzati. Gli eventuali resi autorizzati, dovranno pervenire presso il nostro stabilimento in porto franco. Qualunque pacco contenente merce difettosa, spedito in porto assegnato, verrà respinto. Se il materiale è realmente difettoso, la responsabilità di CGS si limita alla sostituzione delle parti, senza alcun risarcimento per eventuali danni diretti e indiretti causati dall'impiego dei nostri prodotti.

È fatto divieto ai clienti di eseguire qualsiasi tipo di intervento meccanico sui prodotti di nostra produzione.

RECLAMI

I reclami dovranno essere inviati entro otto giorni dal ricevimento della merce con conferma scritta. Qualsiasi tipo di reso del materiale dovrà essere approvato per iscritto dalla nostra direzione commerciale dietro presentazione dell'elenco dei materiali con la motivazione del reso. Le spese di reso sono a carico del cliente salvo accordo specifico tra la direzione commerciale di CGS e l'Acquirente. In caso di reso di un prodotto nuovo e inutilizzato ordinato per errore, il reso sarà a carico del cliente e la società CGS applicherà una penale, a titolo di spese di gestione, proporzionale alla merce resa.

FORO COMPETENTE

Il Tribunale di Novara avrà la competenza giuridica esclusiva a risolvere qualsiasi controversia che potrebbe insorgere.

GARANZIA

Tutti i prodotti CGS S.r.l. sono subordinati a controlli in ogni fase del processo di produzione e sono garantiti per un periodo di tre (3) anni dalla data di acquisto, due (2) anni di garanzia Europea più un (1) anno di estensione gratuita offerta da CGS (farà fede la data della fattura). In assenza di fattura, l'installazione sarà ritenuta avvenuta al massimo entro quattro (4) settimane dalla consegna dei nostri prodotti all'Acquirente. I prodotti colorati sono garantiti due (2) anni. Le parti di ricambio sono garantite due (2) anni.

I casi elencati di seguito sono coperti dalla garanzia:

- Difetti di cromatura.
- Riparazione o sostituzione di prodotti con difetti di fabbricazione riconosciuti dal nostro ufficio tecnico.

Di contro, la garanzia non interverrà nei casi seguenti:

- Errori di installazione e applicazione del prodotto.
- Deterioramento delle superfici cromate dovuto all'utilizzo di prodotti di pulizia contenenti acidi e sostanze abrasive.
- Deterioramento delle superfici presentanti finiture diverse da quelle cromate. La durata dei prodotti è subordinata alla cura e alla delicatezza di utilizzo.
- Deterioramento dovuto a un'installazione impropria.
- Utilizzo improprio del prodotto.
- Riparazioni e manutenzioni effettuate in modo improprio e senza preventiva autorizzazione di CGS.

La garanzia CGS non è rinnovabile.

■ GENERAL TERM OF SALE

These General Terms of Sale (hereinafter «GTS») of the company C.G.S. S.r.l. (hereinafter «CGS») apply to any order made to CGS by a professional buyer (hereinafter «the buyer») for all the deliveries made to all the countries CGS works to. Any order for products or provision of services implies, as an essential and decisive condition, the acceptance by the Buyer, without reservation, of these GTS, which are the basis for the sales negotiations, in compliance with the provisions of the articles of the Code of commerce in force in the various countries, and the related waiver by the Buyer of any other contrary condition, of all the general or special conditions of the Buyer, including any purchase conditions and the purchase orders, the reference contracts and the sales operating contracts, each time these conditions and/or contracts have not received CGS's prior written consent. The sales negotiations between CGS and the Buyer must be carried out with mutual respect for the interests of the Parties, fairly and in good faith.

These GTS may be amended at any time, notwithstanding the fact that any possible amendment will be notified to the Buyer and will take effect from one (1) month from receiving the notification.

PRICE

The prices stated in this Price list are approximate and not binding if not confirmed by CGS. They are intended net of taxes and are expressed in Euro ex-works. This Price list cancels and replaces all the previous editions, notwithstanding errors and omissions. The Price list represents the most up-to-date reference tool. Any errors in this Retail price list do not provide grounds for complaint. Any order made implies the acceptance of all the sales conditions reported below. CGS reserves the right to increase the prices at any time, in particular in case of an increase in production costs linked to an increase in the price of raw materials.

PRODUCTS

1. The products subject to these GTS are defined with reference to CGS catalogue, which may not constitute contractual documents under any circumstance.
2. Products are manufactured with the highest precision possible, notwithstanding the tolerances used in the sector in question. CGS reserves the right to unilaterally modify the features of the products sold, based on improvements recommended by its services, and with no obligation to modify previously delivered products (or in pending orders), and without the prints, descriptions and information reported for advertising purposes on CGS commercial documents being disputed against CGS.

ORDERS

Orders are subject to acceptance by the company and are understood to be subject to the established conditions of sale. Orders are intended as accepted at the prices and conditions in force on the date of the order. Orders and amendments to orders communicated verbally and by telephone must be confirmed by the customer in via post, fax or e-mail. Any cancellations may be authorized only with the prior written approval of CGS, which reserves the right to apply any relevant penalties or reserves the right to refuse them.

CGS reserves the right to ask the Buyer for full payment upon making the order. The order will be considered certain and definitive only after the collection of the invoiced price by CGS.

DELIVERIES / TRANSPORT / TRANSFER OF RISKS

1. Unless otherwise specified, the delivery will be made to the address specified by the Buyer at the time of the order. Regardless of the product shipping method, and deviating from the clause of retention of title established in the GTS below, the risks and hazards are transferred to the Buyer when the goods are handed over to the first courier. If the shipping is delayed due to the behaviour of the Buyer or due to a cause outside CGS's control, the transfer of the risks will take place at the time of the communication to the Buyer of a product supply notification.
2. The delivery delays mentioned in the order confirmation are stated exclusively by way of example, depending on the availability of the products and the transport, unless it is expressly mentioned that these delays are to be considered mandatory.
3. The delivery terms possibly accepted by CGS are suspended in their own right following any event that is out of CGS's control and causes a delay in the delivery, and in particular in cases of force majeure, such

as any event that is beyond CGS's will or the will of one of its suppliers, unpredictable and unstoppable, of any kind, natural disasters, epidemics, bad weather, sabotage, embargoes, strikes, accidents, interruption or delay in the transport and supply of raw materials, energy or components, incidents affecting the machine tools, making the contract impossible to be executed whether temporarily or definitively. The list of the cases of force majeure is not limiting. CGS will inform the Buyer in case an event of force majeure occurs. In this case, the stated delivery terms will be automatically extended proportionally. If, despite the efforts made, CGS found it impossible to deliver the ordered goods due to force majeure, CGS will be exempted from its delivery obligation.

4. Delivery delays may not give rise to penalties, compensation, order cancellation, delivery refusal, suspended invoice payment, unless otherwise agreed by CGS beforehand. This is despite the existence of clauses to the contrary in the purchase conditions of the Buyer. In any event, only the prejudice actually suffered by the Buyer, as demonstrated and assessed, may be subject to claim for compensation, which may in any case be submitted only subject to negotiation with CGS and agreement between the parties. If no agreement can be found, the prejudice will be estimated by an expert entrusted by the Novara commercial court upon the request of the most diligent party.
5. Any change to an order that is made while the order is being executed, even if accepted by CGS, implies an extension of the set delivery term according to the methods communicated by CGS to the Buyer.
6. The Buyer must verify the products at the time of receiving them and immediately express any reservation according to the conditions established under these GTS. Any complaint will be taken into consideration only if the goods are still in the same status they were in when delivered.

EXCLUSION OF PENALTIES

No penalty of any nature may be invoiced or deducted by the Buyer from a balance of products without CGS having been able to verify that the violation and the prejudice claimed by the Buyer exist, by virtue of the articles of the Codes of commerce in force in the various countries CGS works to and without CGS having given its own prior written relevant consent. To this end, the Buyer shall provide CGS with all the documents aimed at allowing a comparative analysis of the violation claimed and stating the prejudice actually suffered. CGS will have sufficient time to analyse the documents sent and inform the Buyer with regard to its agreement or disagreement with the violation claimed and the extent of the compensation demanded. Any direct charge by the Buyer that violates these provisions will be assimilated to a payment incident that will authorise CGS to refuse any new product order and suspend any delivery under way after having notified the Buyer, or suspend the balance of rebates and other financial advantages.

CLAUSES OF RETENTION OF TITLE

Our sales are finalised upon the delivery of the goods; however, the title will be transferred to the Buyer only subsequently to the actual and complete payment of the invoice. Risks are transferred at the time of the delivery and the Buyer must guarantee the goods against any risk, including those of unforeseeable circumstances or force majeure. The Buyer and its insurer forgo in advance any appeal against CGS. CGS authorises the resale of the material delivered before the integral payment of the price, without waiving its property right.

CUSTOMER IDENTIFICATION DATA

The customer is responsible for all identification data supplied to CGS such as, for example: company name, registered office, VAT Reg. number and all the other data requested specifically by current legislation. The customer's data, pursuant to the laws in force in the various countries CGS works to, will be retained and processed in order to comply with legal obligations. All the other uses must be accepted by the customer.

PACKAGING AND SHIPPING

Packaging is prepared by highly specialised personnel. Quoted pricing includes all standard packaging. Extra packaging may be requested by the customer and provided at extra cost borne by the customer. Extra packaging is to be excluded from any refund if made by CGS. Goods travel at the customer's risk and peril. The recipient is expected to check the goods delivered and promptly inform the carrier of any damage at the time of receipt, informing CGS (even if this has been chosen by CGS). Unless otherwise agreed, transport costs will be paid by the customer.

PAYMENT AND DELAYS

1. Any delivery subsequent to an order by the Buyer will result in the issue of an invoice. Invoices are payable to CGS within thirty (30) days from the date of the invoice, via wire transfer, except in case of special conditions agreed between CGS and the Buyer. All the payments shall be made net of the commissions.
2. In case of failed payment upon expiry, by virtue of the articles of the Code of commerce in force in the various countries CGS works to, the payment of default interest will be due in full and without notice from the day after the expiry date stated in the invoice, until the day of full settlement.
3. In no case may the payments due to CGS be suspended or subject to any reduction or offsetting on the exclusive initiative of the Buyer, since CGS's prior written approval is indispensable, and this regardless of any contrary provision that may be included in the Buyer's purchasing conditions.
4. In case of delayed or failed payment, despite the orders to pay sent, CGS reserves the right, in relation to any future order, to enforce the payment guarantees as well as ensure that the delivery of the ordered goods only takes place only upon full payment of the order. For the orders to pay remaining without effect, CGS may request the sale revocation, demand immediate payment for the delivered goods, suspend any delivery and/or cancel any orders under way until all the sums due are settled in full. In case of revocation, the Buyer must refund CGS all the costs linked to the conclusion of the contract as well as the lost earnings. In case of failed total or partial payment at even just one expiry, CGS may recover the goods sold, notwithstanding their ownership by virtue of the provisions under the relevant paragraph of these GTS.

RESPONSIBILITIES

All items forming part of our production are thoroughly tested. Damage caused by an incorrect installation or improper use is not covered by the guarantee, unless otherwise specifically agreed between CGS and the Buyer. CGS does not accept returns of goods unless authorized in writing by CGS. In case of an authorised return, such return must be on the customer's account. Returned goods sent as Ex-Works will not be accepted by CGS. If the material is truly defective, CGS's liability is limited to replacing the parts, with no compensation due for any direct and indirect damage caused by the use of our products. Customers are forbidden to perform any type of mechanical intervention on our products.

COMPLIANTS

Complaints must be sent within eight days from receiving the goods with written confirmation. Any type of return of material must be approved in writing by our marketing management, subject to the presentation of a list of materials with the reason for the return. The return expenses are on the customer's account notwithstanding any specific agreement between CGS's marketing management and the Buyer. In the case of return of a new and unused product ordered by mistake, the return will be on the customer's account and CGS will apply a penalty fee, proportional to the returned goods, as management cost.

COURT OF JURISDICTION

The Court of Novara will have exclusive jurisdiction to settle any dispute that may arise.

GUARANTEE

All products manufactured by CGS are subject to controls in every phase of the production process and are guaranteed for a period of three (3) years from the purchase date (the invoice date will apply). In the absence of an invoice, the installation will be deemed as taking place within a maximum of four (4) weeks from the delivery of our products to the Buyer. The coloured and electronic products are guaranteed for two (2) years. Spare parts are guaranteed two (2) years.

The cases listed below are covered by the guarantee:

- Chrome-plating defects.
- Repair or replacement of products with manufacturing defects acknowledged as such by our technical office.

On the other hand, the guarantee will not be valid in the following cases:

- Errors during installation and application of the product.
- Deterioration of the chromed surface due to the use of cleaning

products containing acids or abrasive substances.

- Deterioration of the surface presenting finishes other than chrome. The duration of the products is subject to the type of care and gentle use.
- Deterioration due to incorrect installation.
- Incorrect use of the product.
- Repairs and maintenance performed in an incorrect manner and without the prior authorisation of CGS.

The guarantee by CGS cannot be renewed.

CGS



C.G.S. SRL

via torino 9/a, 28060 cureggio (no) italia
office +39 0322 839971
fax +39 0322 839973
info@cgsmixer.com
cgsmixer.com

